

## ENGINE TOOL PARTS LIST

ENGINE CHAIN SAW  
Model CS 33EA

2009·3·3  
(E1)

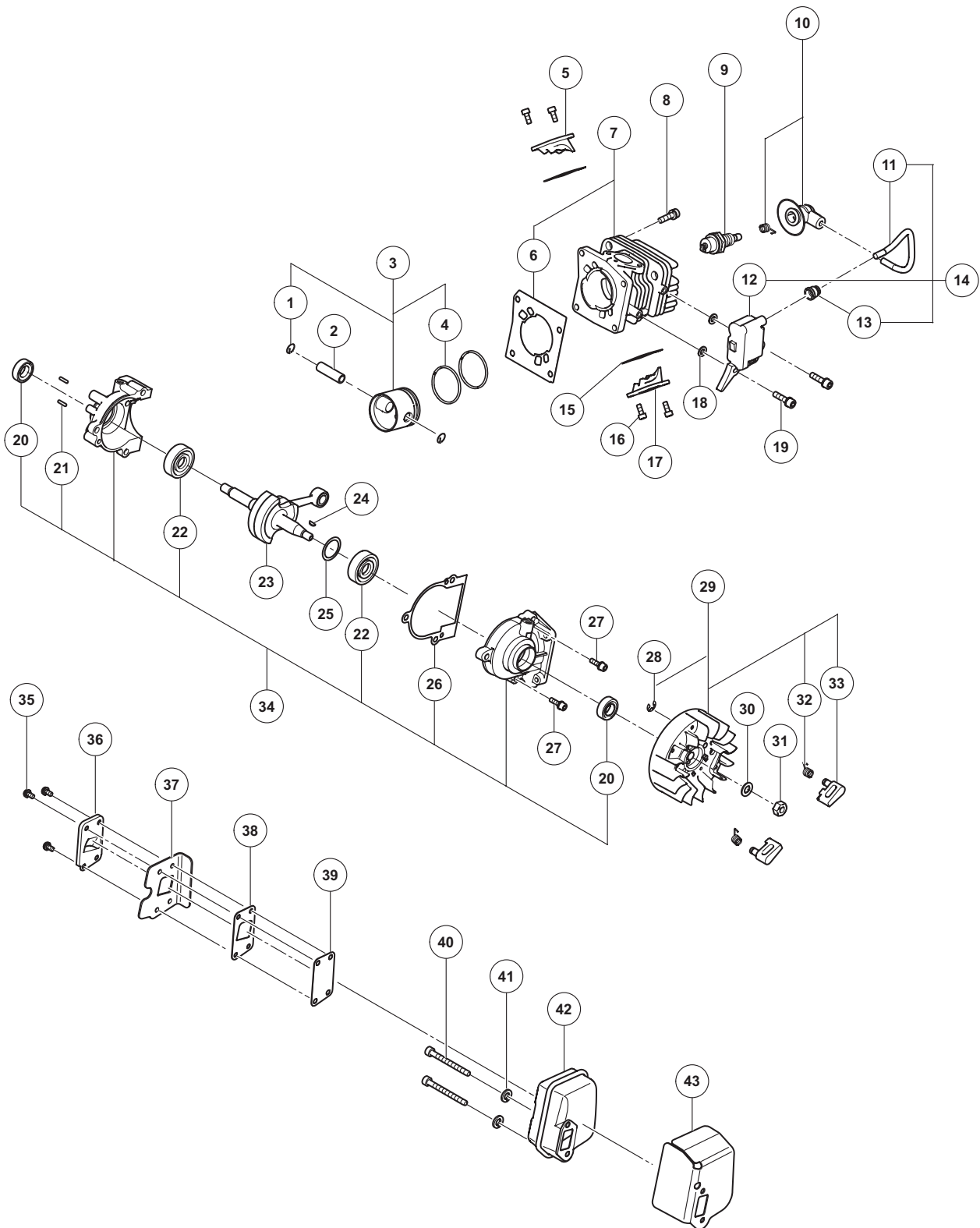

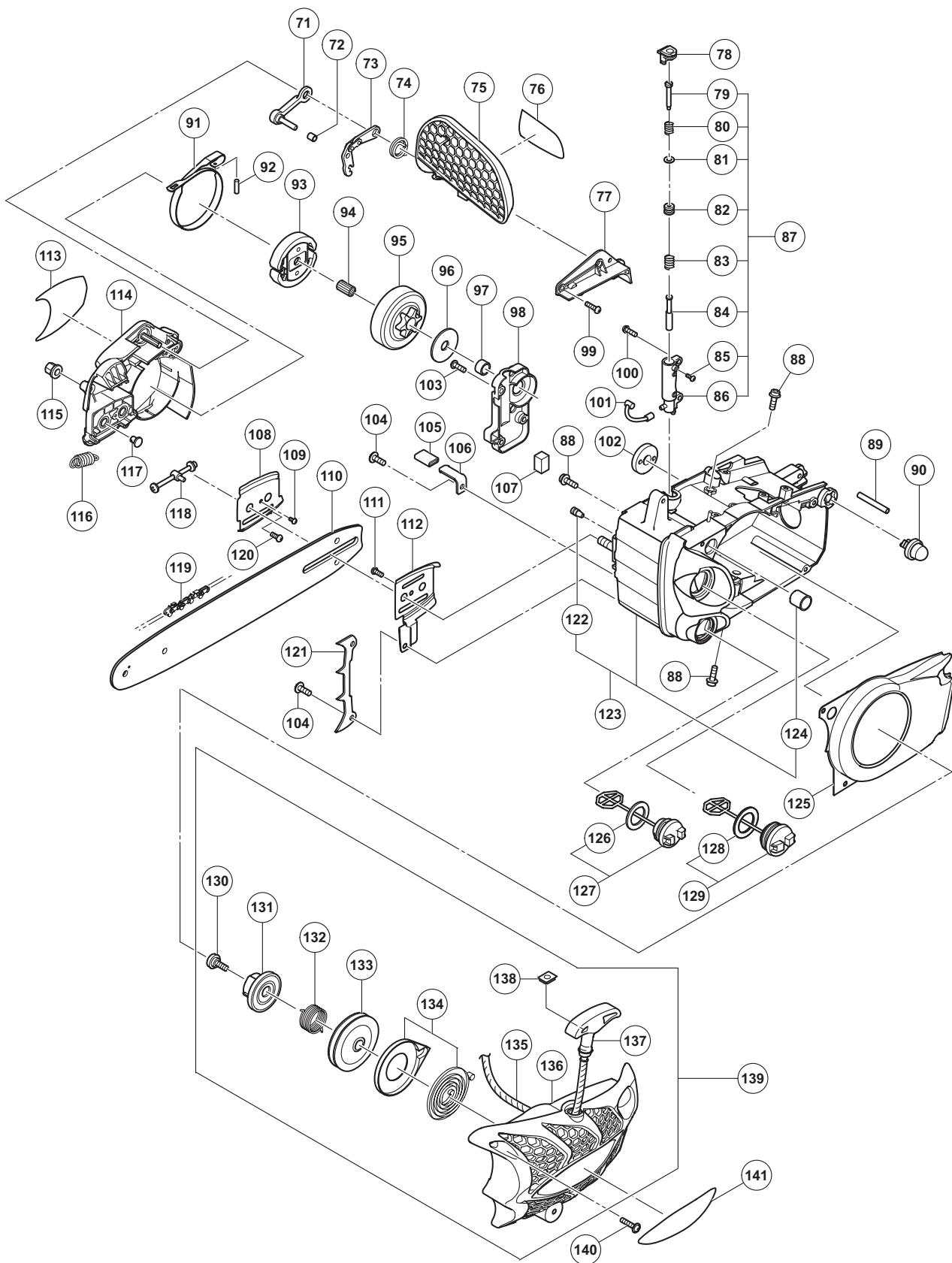

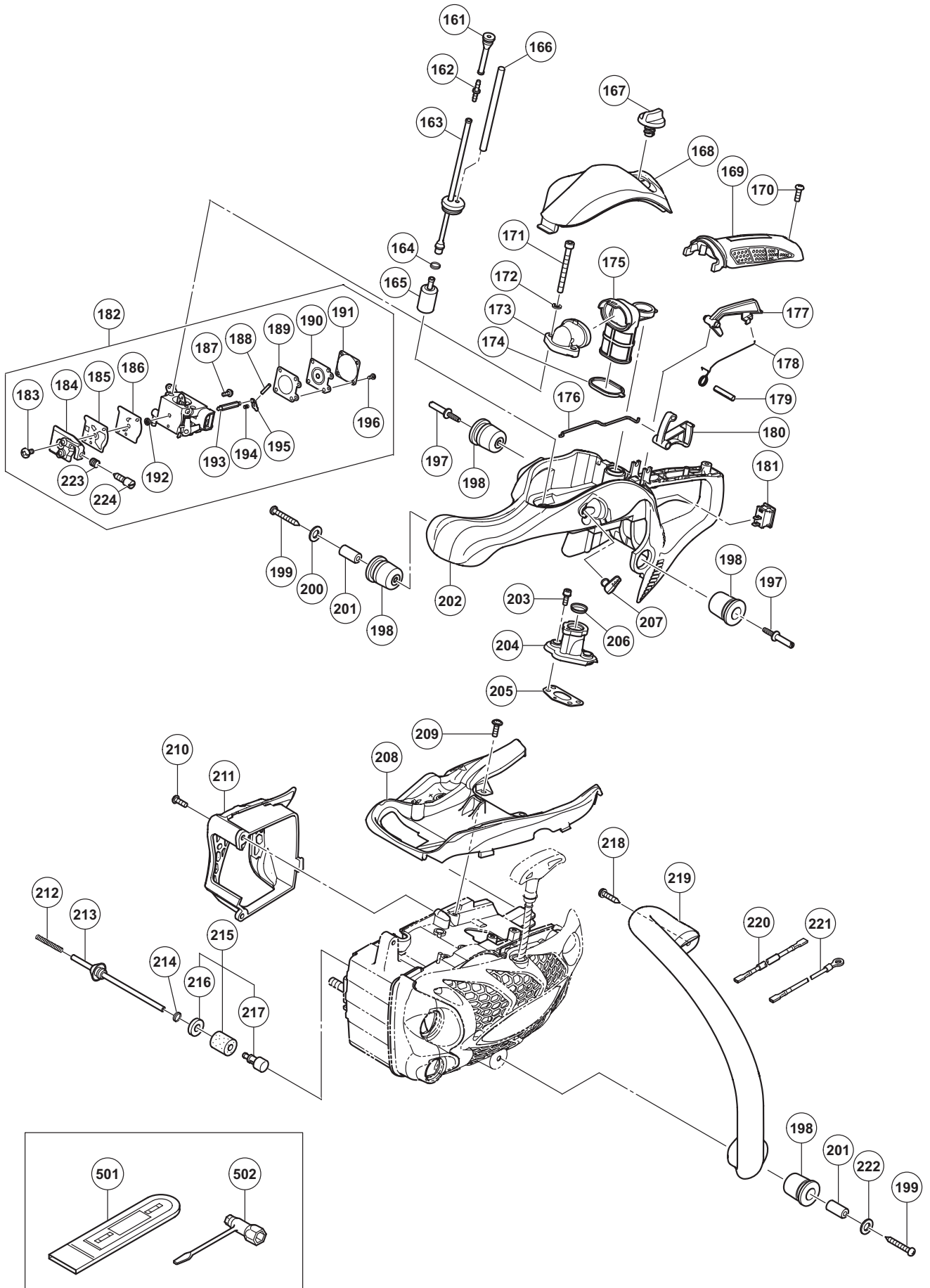

**PARTS**

CS 33EA

ITEM NO.	CODE NO.	DESCRIPTION	NO. USED	REMARKS
1	668-5078	CIRCLIP	2	
2	668-5079	PISTON PIN	1	
3	668-5080	PISTON SET	1	INCLUD. 1,4
4	668-5081	PISTON RING	2	
5	668-5082	SCAVENGING COVER (B)	1	
6	668-5083	CYLINDER PACKING	1	
7	668-5084	CYLINDER SET	1	INCLUD. 6
8	668-4668	HEX. HOLE BOLT M5X20/S	4	
* 9	668-5085	SPARK PLUG BPM6A	1	FOR USA
* 9	668-5086	SPARK PLUG BPMR6A	1	FOR EUROPE, AUS
10	668-5087	SPARK PLUG CAP ASS'Y	1	
11	668-5088	HIGH VOLTAGE CORD	1	
12	668-5089	IGNITION COIL COMP.	1	
13	668-4602	RUBBER CAP	1	
14	668-5091	IGNITION COIL ASS'Y	1	INCLUD. 11-13
15	668-5092	COVER PACKING (A)	2	
16	668-5093	HEX. SOCKET HD. BOLT M4X10	4	
17	668-5094	SCAVENGING COVER (A)	1	
18	668-4600	WASHER	2	
19	668-4599	HEX. HOLE BOLT M4X18/WS	2	
20	668-4607	OIL SEAL TB 12227	2	
21	668-5095	NEEDLE ROLLER 2.5X9.8	2	
22	668-5096	BALL BEARING 6201 A2C3	2	
23	668-5097	CRANK SHAFT COMP.	1	
24	668-4899	WOODRUFF KEY 3X13X4.5	1	
25	668-5098	SHIM S T0.2	1	
25	668-5099	SHIM S T0.3	1	
26	668-5100	CRANK CASE PACKING	1	
27	668-4668	HEX. HOLE BOLT M5X20/S	3	
28	668-5101	D4E RETAINING RING	2	
29	668-5102	MAGNETO ROTOR ASS'Y	1	INCLUD. 28, 32, 33
30	668-5103	BOLT WASHER M7	1	
31	668-5104	FLYWHEEL NUT	1	
32	668-5105	STARTER PAWL SPRING	2	
33	668-5106	STARTER PAWL	2	
34	668-5107	CRANK CASE ASS'Y	1	INCLUD. 20-22, 26
* 35	986-662	MACHINE SCREW (W/WASHERS) M4X10	4	FOR EUROPE, USA
* 35	668-5109	MACHINE SCREW (W/SP. WASHER) M4X8	4	FOR AUS, RUS
36	668-5110	EXHAUST PIPE	1	
37	668-5111	MUFFLER SPECIAL PACKING	1	
* 38	668-5112	GAUZE FIXING PLATE	1	EXCEPT FOR AUS, RUS
* 39	668-5113	MUFFLER GAUZE	1	EXCEPT FOR AUS, RUS
40	668-5114	HEX. SOCKET HD. BOLT M5X50	2	
41	668-4661	WASHER 5	2	
* 42	668-5115	MUFFLER COMP.	1	FOR EUROPE, USA
* 42	668-5116	MUFFLER COMP.	1	FOR AUS, RUS
43	668-5117	MUFFLER PACKING	1	
71	668-5119	BRAKE SUPPORT PLATE COMP.	1	
72	668-5120	COLLAR	1	
73	668-5121	BRAKE LINK COMP.	1	

**PARTS**

CS 33EA

ITEM NO.	CODE NO.	DESCRIPTION	NO. USED	REMARKS
74	668-5122	BRAKE LEVER SPRING	1	
75	668-5264	BRAKE HANDLE	1	
76		CAUTION LABEL	1	
77	668-5126	BRAKE LINK COVER	1	
78	668-5127	OIL ADJUST GROMMET	1	
79	668-5128	OIL PUMP ADJUSTER	1	
80	668-5129	ADJUSTER SPRING	1	
81	668-5070	BOLT WASHER M4	1	
82	668-5130	OIL PUMP ADJUST CAP	1	
83	668-5131	PUMP GEAR SPRING	1	
84	668-5132	PUMP GEAR COMP.	1	
85	668-5133	MACHINE SCREW M3X8	1	
86	668-5134	OIL PUMP CASE COMP.	1	
87	668-5135	OIL PUMP CASE ASS'Y	1	INCLUD. 79-86
88	668-5136	SEAL LOCK BOLT M5X15	5	
89	668-5267	FUEL PIPE 2.5X4X90	1	
90	668-5139	PRIMING PUMP COMP.	1	
91	668-5140	BRAKE BAND	1	
92	668-5141	NEEDLE ROLLER 3X9.8	1	
93	668-5142	CLUTCH COMP.	1	
94	668-5143	NEEDLE BEARING	1	
95	668-5144	CLUTCH HOUSING COMP.	1	
96	668-5145	CLUTCH WASHER	1	
97	668-5146	CRANK SHAFT COLLAR	1	
98	668-5147	OIL PUMP COVER	1	
99	668-5148	TAPPING SCREW D4X15	3	
100	668-5149	MACHINE SCREW (W/SP. WASHER) M4X14	2	
101	668-5150	OIL PIPE (A)	1	
102	668-5151	SCREW GEAR	1	
103	668-5152	TAPPING SCREW D4.5X14	3	
104	668-5153	TAPPING SCREW D4.5X14	3	
105	668-5154	FUEL PIPE	1	
106	668-5155	CHAIN CATCHER	1	
107	668-5156	AIR VENT SPONGE	1	
108	668-5157	GUIDE PLATE (B)	1	
109	668-5158	TAPPING SCREW D3X8	1	
* 110	668-5294	CHAIN BAR 12 INCH 3/8 SP	1	FOR EUROPE, USA
* 110	668-5295	CHAIN BAR 14 INCH 3/8 SP	1	FOR EUROPE, AUS, USA
111	668-5161	TAPPING SCREW D4X10	1	
112	668-5162	GUIDE PLATE (A)	1	
113		NAME PLATE (CS 33EA)	1	
114	668-5165	SIDE COVER COMP.	1	
115	668-5166	NUT	2	
116	668-5167	BRAKE SPRING	1	
117	668-5168	GEAR (A)	1	
118	668-5169	CHAIN PULLER COMP.	1	
* 119	668-5170	SAW CHAIN (3/8X12") 91VG-45	1	FOR EUROPE, USA
* 119	668-5171	SAW CHAIN (3/8X14") 91VG-52	1	FOR EUROPE, AUS, USA
120	668-5161	TAPPING SCREW D4X10	1	
121	668-5270	SPIKE	1	

## PARTS

CS 33EA

ITEM NO.	CODE NO.	DESCRIPTION	NO. USED	REMARKS
122	668-5173	AIR VENT VALVE (B)	1	
123	668-5271	ENGINE CASE ASS'Y	1	INCLUD. 122, 124
124	668-5175	INNER CAP ASS'Y	1	
125	668-5176	AIR DEFLECTOR	1	
126	668-5177	OIL TANK CAP PACKING	1	
127	668-5178	OIL TANK CAP ASS'Y	1	INCLUD. 126
128	668-5179	TANK CAP PACKING	1	
129	668-5180	TANK CAP ASS'Y	1	INCLUD. 128
130	668-4679	SET SCREW	1	
131	668-5182	CAM PLATE	1	
132	668-5183	DAMPER SPRING	1	
133	668-5184	STARTER PULLEY	1	
134	668-5185	SPRING CASE ASS'Y	1	
135	668-5186	ROPE	1	
136	668-5187	FAN CASE COMP.	1	
137	668-5188	STARTER HANDLE	1	
138	668-5189	PLATE	1	
139	668-5190	RECOIL STARTER ASS'Y	1	INCLUD. 130-138
140	668-5191	TAPPING SCREW D4.5X20	4	
141		HITACHI LABEL (C)	1	
161	668-5272	RUBBER PIPE	1	
162	668-5196	PIPE JOINT	1	
163	668-5197	SHIELD TUBE ASS'Y	1	
164	668-5198	CLIP D6	1	
165	668-5199	PUMP FILTER BODY ASS'Y	1	
166	668-5200	FUEL PIPE 2.5X4X260	1	
167	668-5228	CLEANER KNOB	1	
168	668-5273	CLEANER COVER	1	
169	668-5274	REAR HANDLE GRIP COMP.	1	
170	668-5275	TAPPING SCREW D5X14	1	
171	668-5114	HEX. SOCKET HD. BOLT M5X50	2	
172	668-5226	WASHER M5 (BLACK)	2	
173	668-5276	AIR CLEANER BASE	1	
174	668-5277	CLEANER CAP	1	
175	668-5278	CLEANER ELEMENT COMP.	1	
176	668-5279	THROTTLE ROD	1	
177	668-5280	TRIGGER LOCKOUT	1	
178	668-5281	THROTTLE LEVER SPRING	1	
179	668-5282	SPRING PIN 5X25	1	
180	668-5283	THROTTLE LEVER	1	
181	668-5239	STOP SWITCH	1	
* 182	668-5284	CARBURETOR ASS'Y WT-956	1	INCLUD. 183-196, 223, 224 FOR EUROPE, USA
* 182	668-5285	CARBURETOR ASS'Y WT-959	1	INCLUD. 183-196, 223, 224 FOR AUS, RUS
183	668-5210	SCREW	1	
184	668-5211	PUMP BODY	1	
185	668-5212	PUMP GASKET	1	
186	668-5213	PUMP DIAPHRAGM	1	
187	668-5218	HINGE PIN SET SCREW	1	
188	668-5219	HINGE PIN	1	
189	668-5220	DIAPHRAGM PACKING	1	

**PARTS**

CS 33EA

ITEM NO.	CODE NO.	DESCRIPTION	NO. USED	REMARKS
190	668-4690	METERING DIAPHRAGM	1	
191	668-5222	DIAPHRAGM COVER	1	
192	668-4700	INLET SCREEN	1	
193	668-5215	NEEDLE VALVE	1	
194	668-5216	VALVE SPRING	1	
195	668-5217	CONTROL LEVER	1	
196	668-5223	SET SCREW	4	
197	668-5286	DAMPER SET BOLT	2	
198	668-5236	BUMPER COMP.	4	
199	668-5233	TAPPING SCREW D5X45	2	
200	668-5287	WASHER	1	
201	668-5235	COLLAR 28.2	2	
202	668-5288	REAR HANDLE (A) COMP.	1	
203	668-4595	HEX. HOLE BOLT M4X12/S	2	
204	668-5289	INTAKE COMP.	1	
205	668-5205	INTAKE PACKING	1	
206	668-5290	INLET MANIFOLD RING	1	
207	668-5206	CHOKE LEVER	1	
208	668-5291	ENGINE CASE COVER	1	
209	668-5153	TAPPING SCREW D4.5X14	4	
210	668-5152	TAPPING SCREW D4.5X14	2	
211	668-5245	MUFFLER COVER	1	
212	668-5246	PROTECTIVE COIL	1	
213	668-5247	SHIELD TUBE ASS'Y	1	
214	668-5198	CLIP D6	1	
215	668-5249	OIL FILTER BODY ASS'Y	1	INCLUD. 216, 217
216	668-4661	WASHER 5	1	
217	668-5248	OIL FILTER BODY	1	
218	302-089	TAPPING SCREW (W/FLANGE) D5X20 (BLACK)	2	
219	668-5292	FRONT HANDLE	1	
220	668-5293	CORD 195MM	1	
221	668-5252	CORD 180MM	1	
222	668-5234	WASHER	1	
223	668-5297	IDLE ADJUST SPRING	1	
224	668-5298	IDLE ADJUST SCREW	1	

