

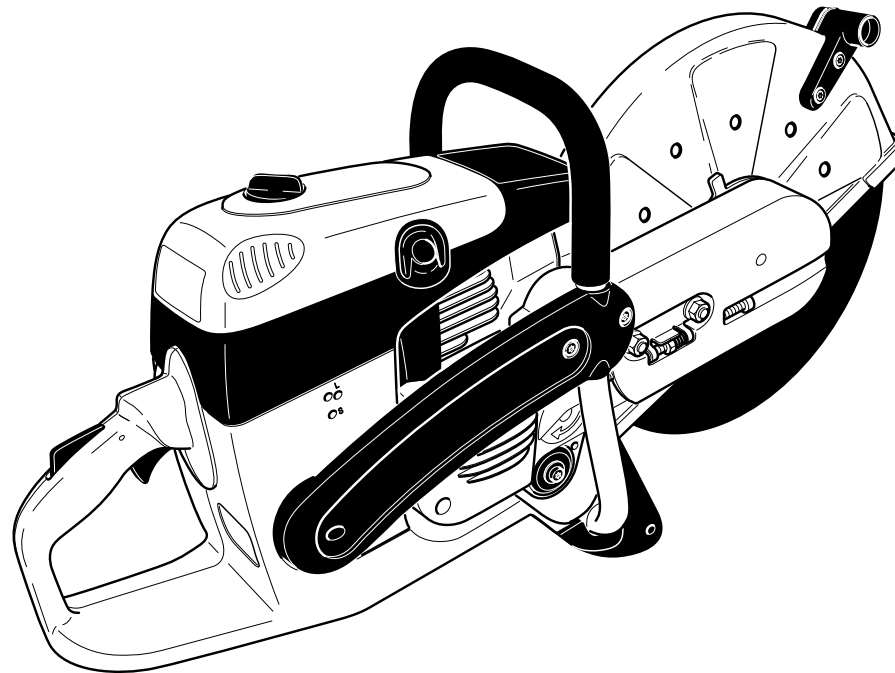

Spare Parts List
Ersatzteilliste
Liste de pièces détachées
Lista de piezas de repuesto

2014-03



EK7300
EK7301
EK8100

995700586 (D, GB, F, E)

EK7300, EK7301, EK8100

1

Tankeinheit und Handgriffe
Tank and handle grips
Réservoir et poignées
Depósito y mangos

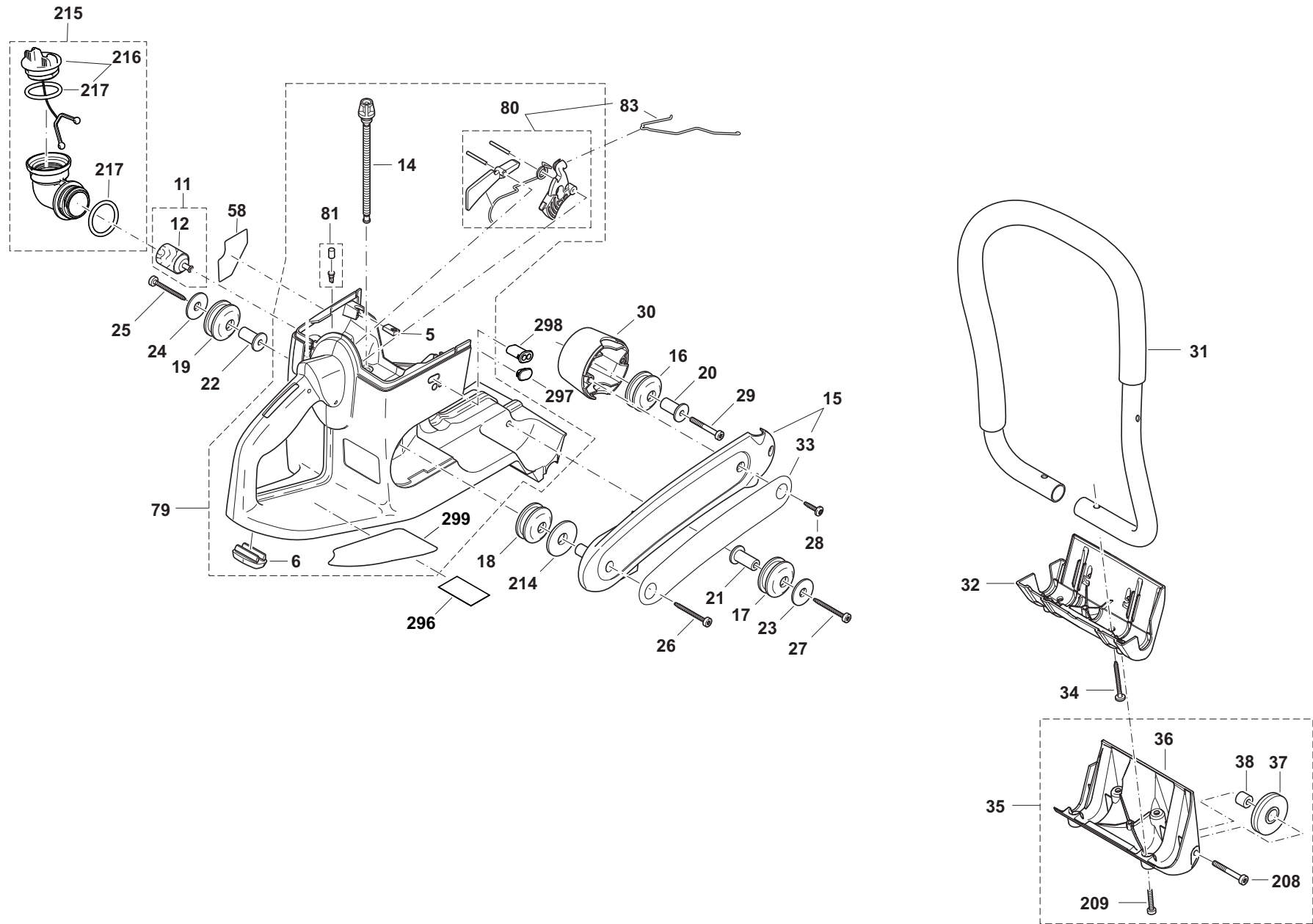

EK7300, EK7301, EK8100

1

Tankeinheit und Handgriffe
Tank and handle grips
Réservoir et poignées
Depósito y mangos



Seite / Page	Pos.	EK7300	EK7301	EK8100	Teil-Nr. Part No. No. de pièce No. de pieza	Hinweise Notes Renseign. Nota	Bezeichnung	Spezifikation Specification	Description	Désignation	Denominación
1	5	4	4	4	394 114 100		SCHRAUBEINSATZ		SCREW PLUG	EMBOUT DE VISSAGE	ALOJAMIENTO DE TORNILLOS
1	6	1	1	1	394 114 070		GUMMIFUß		RUBBER FOOT	PIED, CAOTCHOUC	PIE, GOMA
1	11	1	1	1	010 114 010		SAUGKOPF KPL.		SUCTION HEAD	TETE D'ASPIRATION	CABEZA DE ASPIRACION
1	12	1	1	1	010 114 020		REPARATUR-SATZ, FILTER (JE 5 STCK.)	for 010114010	REP. KIT, FILTER (5 OF EACH)	JEU DE RÉPARAT., FILTRE	JUEGO DE REPARAR, FILTRO
1	14	1	1	1	965 404 913		SAUGSCHLAUCH KRAFTSTOFF	EPA code	FUEL LINE	CONDUITE CARB.	TUBO COMB.
1	15	1	1	1	395 310 600	2010 =>	SEITENSTREBE, GEÄTZT	MAKITA, black, etched	BRACKET	SUPPORT	SOPORTE
1	16	1	1	1	965 403 535		SCHWINGUNGSDÄMPFER		RUBBER BUFFER	AMORTISSEUR	AMORTIGUADOR
1	17	1	1	1	965 403 535		SCHWINGUNGSDÄMPFER		RUBBER BUFFER	AMORTISSEUR	AMORTIGUADOR
1	18	1	1	1	965 403 535		SCHWINGUNGSDÄMPFER		RUBBER BUFFER	AMORTISSEUR	AMORTIGUADOR
1	19	1	1	1	965 403 535		SCHWINGUNGSDÄMPFER		RUBBER BUFFER	AMORTISSEUR	AMORTIGUADOR
1	20	1	1	1	394 114 281		ACHSE FÜR DÄMPFER		AXLE	AXE	EJE
1	21	1	1	1	394 114 281		ACHSE FÜR DÄMPFER		AXLE	AXE	EJE
1	22	1	1	1	394 114 281		ACHSE FÜR DÄMPFER		AXLE	AXE	EJE
1	23	1	1	1	900 005 078		ANLAGESCHEIBE		WASHER	RONDELLE	ARANDELA
1	24	1	1	1	900 005 078		ANLAGESCHEIBE		WASHER	RONDELLE	ARANDELA
1	25	1	1	1	913 455 454		SCHRAUBE	5,5x45	SCREW	VIS	TORNILLO
1	26	1	1	1	913 455 454		SCHRAUBE	5,5x45	SCREW	VIS	TORNILLO
1	27	1	1	1	913 455 454		SCHRAUBE	5,5x45	SCREW	VIS	TORNILLO
1	28	2	2	2	913 455 204		SCHRAUBE	5,5x20	SCREW	VIS	TORNILLO
1	29	1	1	1	908 305 405		SCHRAUBE INNEN6RD ZK	M5x40	H.L. SOCKET HEAD BOLT	VIS	TORNILLO
1	30	1	1	1	395 310 020	2010 =>	AUFNAHMETOPF, SCHWARZ, GEÄTZT	black, etched	POT	CAPUCHON	POTE
1	31	1	1	1	394 310 101		RUNDUMGRIFF KPL.		WRAP AROUND HANDLE ASSY.	POIGNÉE CIRCULAIRE CPL.	MANGO CIRCULAR CPL.
1	32	1	1	1	395 250 020		STANDFUSS		STAND SET	PIED	PIE
1	33	1	1	1	980 115 215		SCHILD	MAKITA	LABEL	PLAQUE	CALCOMANIA
1	34	2	2	2	913 455 454		SCHRAUBE	5,5x45	SCREW	VIS	TORNILLO
1	35	1	1	1	394 114 272	Acc.	STANDFUß MIT ROLLEN KPL.		FOOT CPL.	PIED CPL.	PIE CPL.
1	37	2	2	2	394 114 230	Acc.	ROLLE		ROLLER	ROULEAU	RUEDA
1	38	2	2	2	394 114 240	Acc.	BUCHSE		BUSHING	DOUILLE	CASQUILLO
1	58	1	1	1	980 115 100		AUFKLEBER	MIX, USA-CDN-AUS	LABEL	ÉTIQUETTE	ETIQUETA
1	79	1	1	1	395 114 600	2010 =>	TANK KPL. MIT MECHANIK	blue, highly polished	TANK CPL.	RÉSERVOIR CPL.	DEPÓSITO CPL.
1	79	1	1	1	395 114 603	2012-04 =>	TANK KPL. MIT MECHANIK	blue, highly polished	TANK CPL.	RÉSERVOIR CPL.	DEPÓSITO CPL.
1	79	1	1	1	395 114 641		TANK KPL. MIT MECHANIK, BLAU	USA (EPA), INCL.296	TANK CPL., BLUE	RÉSERVOIR CPL., BLEU	DEPÓSITO CPL., AZUL
1	80	1	1	1	957 117 040		GASMECHANIK KPL.		THROTTLE MECHANISM, CPL.	MÉCANIQUE DE DÉCLEN. CPL.	MECANISMO ACELERADOR, CPL.
1	81	1	1	1	170 175 010		SATZ BELÜFTUNGSVENTIL		AIR VALVE CPL.	SOUPAPE D'AERATION CPL.	VÁLVULA VENTILACION CPL.
1	83	1	1	1	395 117 011		GASGESTÄNGE		THROTTLE LINKAGE	TRINGLE D' ACCÉLÉRATION	VARILLA ACELERADOR
1	208	2	2	2	908 006 356	Acc.	SCHRAUBE	M6X35	SCREW	VIS	TORNILLO
1	209	4	4	4	908 905 165		INNENSTERN-SCHRAUBE	5x16	SCREW	VIS	TORNILLO
1	214	1	1	1	900 005 076		ANLAGESCHEIBE		WASHER	RONDELLE	ARANDELA
1	215	1	1	1	395 114 300	Acc.	WINKELTANKVERSCHLUß KPL.		ANGULAR UNION ASSY.	MANCHON COUDÉ CPL.	CIERRE ANGULAR CPL.
1	216	1	1	1	181 114 202		TANKDECKEL KPL.		TANK CAP CPL.	BOUCHON RESERVOIR CPL.	TORNILLO DE CIERRE CPL.

EK7300, EK7301, EK8100

1

Tankeinheit und Handgriffe
Tank and handle grips
Réservoir et poignées
Depósito y mangos

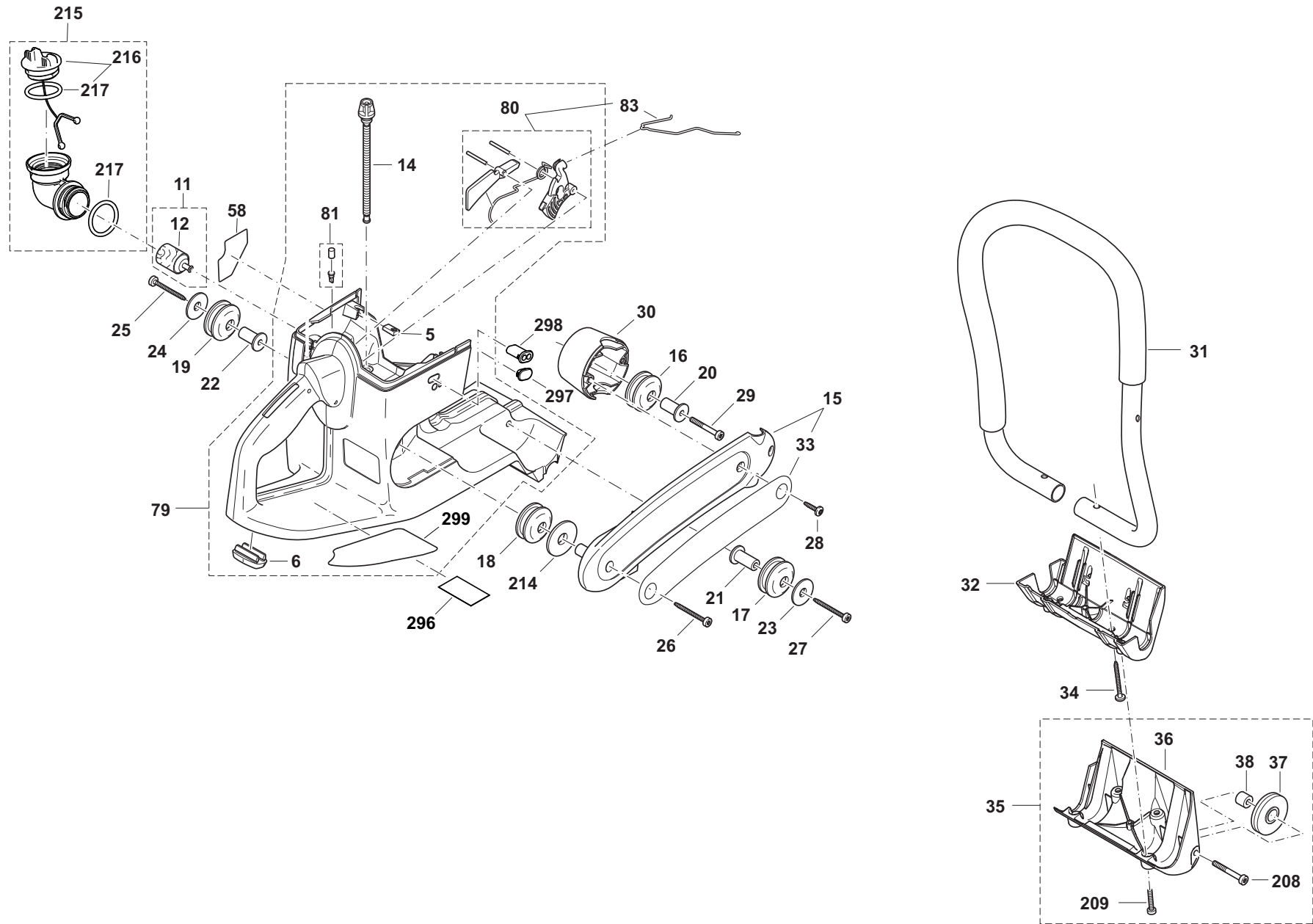

EK7300, EK7301, EK8100

1

Tankeinheit und Handgriffe
 Tank and handle grips
 Réservoir et poignées
 Depósito y mangos



Seite / Page	Pos.	EK7300	EK7301	EK8100	Teil-Nr. Part No. No. de pièce No. de pieza	Hinweise Notes Renseign. Nota	Bezeichnung	Spezifikation Specification	Description	Désignation	Denominación
1	217	2	2	2	963 229 036		O-RING	29,3X3,6	PACKING RING	BAGUE-JOINT	ANILLO DE GUARNICION
1	296	1	1	1			AUFKLEBER TANK	USA - EVAPORATION MAKITA	LABEL, TANK	PLAQUE, RÉSERVOIR	CALCOMANIA, DEPÓSITO
1	297	1	1	1	395 114 040		VERSCHLUßSTOPFEN	EU, USA	PLUG	BOUCHON	TAPON
1	298	1	1	1	170 118 031		FÜHRUNG	H / L (non regulated market)	ADJUSTING GUIDE	GUIDAGE D' AJUSTAGE	GUÍA DE AJUSTE
1	299	1	1	1	980 115 699		AUFKLEBER	START	LABEL	ÉTIQUETTE	ETIQUETA

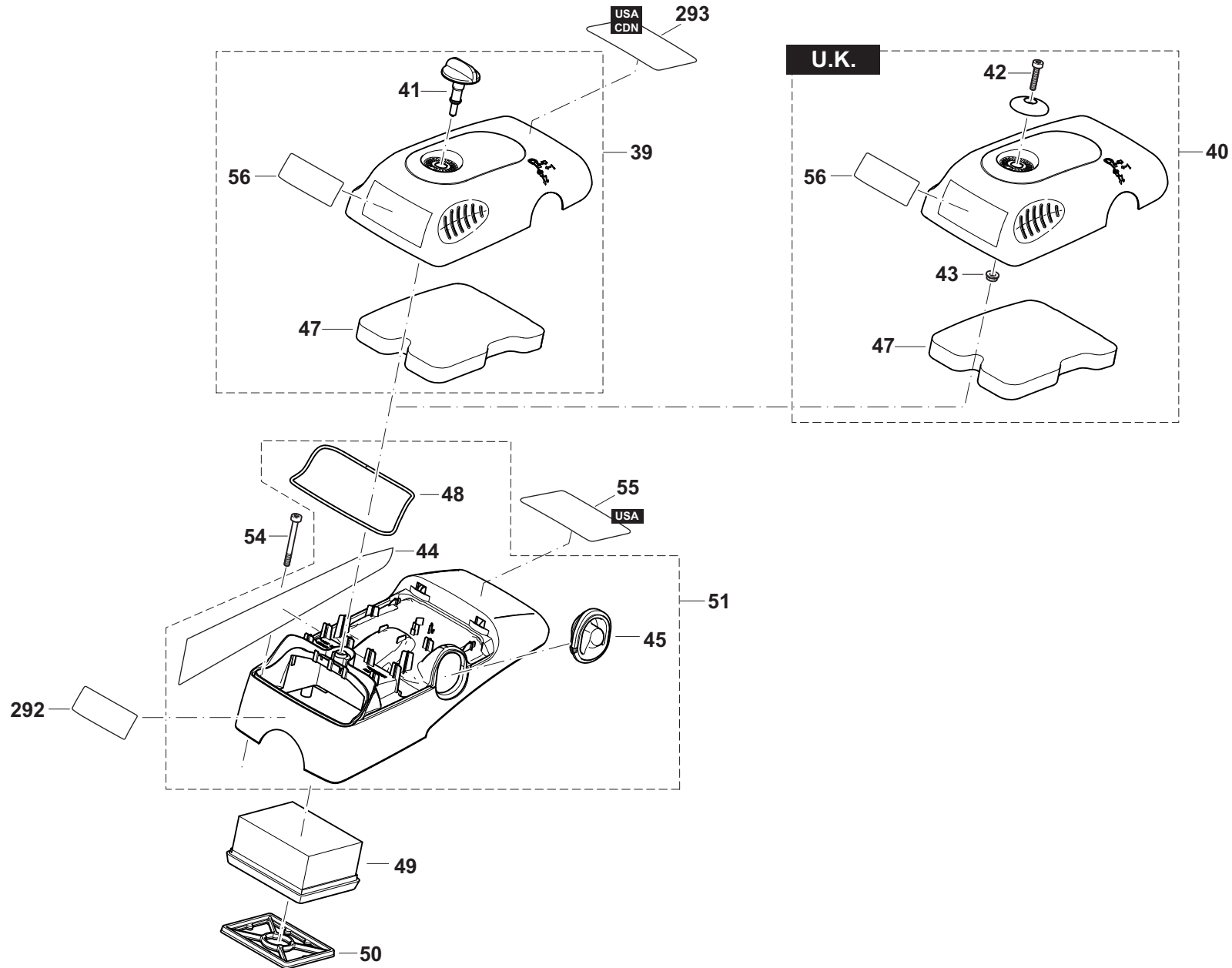

EK7300, EK7301, EK8100

2

Abdeckhaube, Luftfilter
Hood, air filter
Capot protecteur, filtre à air
Cubierta protectora, filtro de aire



Seite / Page	Pos.	EK7300	EK7301	EK8100	Teil-Nr. Part No. No. de pièce No. de pieza	Hinweise Notes Renseign. Nota	Bezeichnung	Spezifikation Specification	Description	Désignation	Denominación
2	39	1	1	1	395 118 122		FILTERDECKEL KPL., SCHWARZ, GEÄTZT	black, etched, incl. Pos. 47	COVER ASSY.	CAPOT CPL.	CUBIERTA CPL.
2	40	1	1		957 118 020	U.K. 2010 =>	FILTERDECKEL KPL., SCHWARZ, GEÄTZT	black, etched, incl. Pos. 47	FILTER COVER ASSY.	CAPOT FILTRE CPL.	CUBIERTA P. FILTRE CPL.
2	41	1	1	1	395 118 010		VERSCHLUßKNOPF		FIXING	FERMETURE	CIERRE
2	42	1	1		395 118 131	U.K.	SENKKOPFSCHRAUBE	M6x50	COUNTERSUNK SCREW	BOULON À TÊTE FRAISÉE	TORNILLO DE CABEZA AVELLANADA
2	43	1	1		920 406 000	U.K.	SECHSKANTMUTTER	M 6	HEX NUT	ECROU HEXAGONAL	TUERCA HEXAGONAL
2	44	1	1	1	980 115 870		SICHERHEITSAUFKLEBER		SAFETY LABEL	PLAQUE	CALCOMANIA
2	44	1	1	1	980 115 902	RU	SICHERHEITSAUFKLEBER	RU	SAFETY LABEL	PLAQUE	CALCOMANIA
2	45	1	1	1	395 118 050		GUMMITEIL	DEKO	RUBBER PART	ÉLASTIQUE PART	PIEZA DE GOMA ELÁSTICA
2	47	1	1	1	395 173 081		VORFILTER		PREFILTER	PREFILTRE	PRIMER FILTRO
2	47	1	1	1	957 173 611		FILTERSET	5+1 MAKITAINC. 5x47 + 1x49	FILTER-SET	JEU DE FILTRE POUR DECOUPEUSE	JUEGO DE FILTROS CORTADORAS
2	48	1	1	1	395 118 021		DICHTSCHNUR		PACKING RING	BAGUE-JOINT	ANILLO DE GUARNICIÓN
2	49	1	1	1	395 173 011		LUFTFILTEREINSATZ		AIR FILTER	FILTRE À AIR	FILTRO DE AIRE
2	49	1	1	1	957 173 611		FILTERSET	5+1 MAKITA	FILTER-SET	JEU DE FILTRE POUR DECOUPEUSE	JUEGO DE FILTROS CORTADORAS
2	50	1	1	1	395 173 020		INNENFILTER		INNER FILTER	FILTRE INTÉRIEUR	FILTRO DE AIRE INTERIOR
2	51			1	395 118 211	RU	ABDECKHAUBE KPL., SCHWARZ, GEÄTZT	black, etched (RU)	HOOD CPL.	CAPOT CPL.	TAPA CPL.
2	51	1	1	1	395 118 085		ABDECKHAUBE KPL., SCHWARZ, GEÄTZT		HOOD CPL.	CAPOT CPL.	TAPA CPL.
2	54	4	4	4	908 605 505		INNENSTERN-SCHRAUBE	M5x50	SCREW	VIS	TORNILLO
2	55	1			980 115 559		AUFKLEBER ABDECKHAUBE	EK7300	LABEL	PLAQUE	CALCOMANIA
2	55		1		980 115 560		AUFKLEBER ABDECKHAUBE	EK7301	LABEL	PLAQUE	CALCOMANIA
2	56	1	1	1	980 114 999		SCHILD	2-TAKT MIX	LABEL	PLAQUE	CALCOMANIA
2	292	1	1	1	980 115 809		SICHERHEITSAUFKLEBER	US WARNING SPARKS	CAUTION LABEL	PLAQUE	CALCOMANIA
2	293	1	1	1	980 115 602		STARTAUFKLEBER	CDN	LABEL	PLAQUE	CALCOMANIA
2	293	1	1	1	980 115 607		STARTAUFKLEBER	USA	LABEL	PLAQUE	CALCOMANIA

EK7300, EK7301, EK8100

3

Schalldämpfer, Ansaugkrümmer
Muffler, connecting muff
Pot d' échappement, manchon de jonction
Silencioso, manguito de conexión

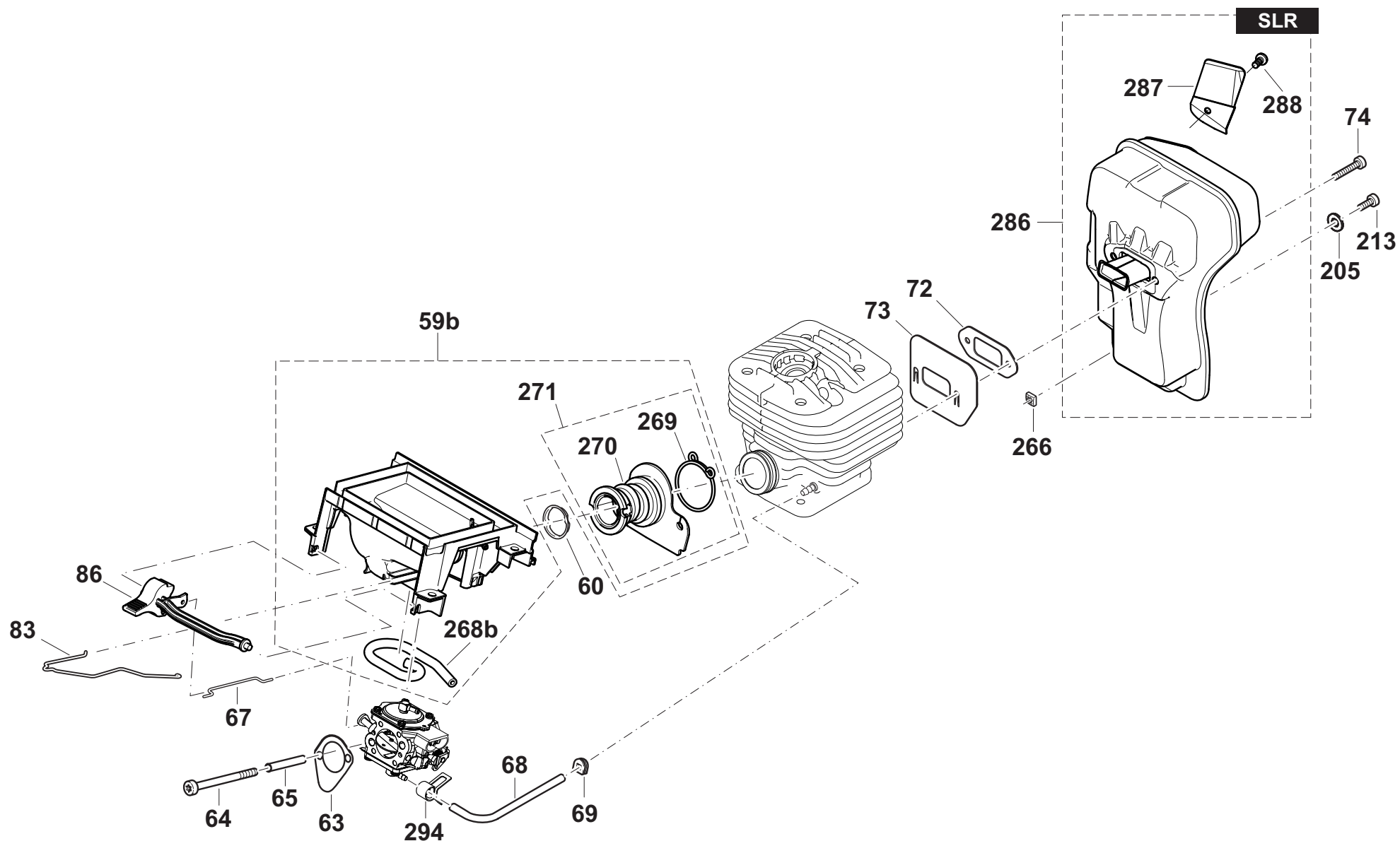

EK7300, EK7301, EK8100

3

Schalldämpfer, Ansaugkrümmer
Muffler, connecting muff
Pot d' échappement, manchon de jonction
Silencioso, manguito de conexión



Seite / Page	Pos.	EK7300	EK7301	EK8100	Teil-Nr. Part No. No. de pièce No. de pieza	Hinweise Notes Renseign. Nota	Bezeichnung	Spezifikation Specification	Description	Désignation	Denominación
3	59b	1	1	1	395 171 072		ANSAUGKRÜMMER KPL.		CONNECTING MUFF CPL.	MANCHON DE JONCTION CPL.	MANGUITO DE CONEXIÓN CPL.
3	60	1	1	1	024 131 032		EINSATZ FÜR ANSAUGSCHLAUCH		INSERT FOR SUCTION HOSE	PIÈCE P. TUYAU	SUPLEMENTO P. TUBO
3	63	1	1	1	965 518 120		DICHTUNG		GASKET	JOINT	JUNTA
3	64	2	2	2	908 204 555		INNENSTERN-SCHRAUBE	M4x55	SCREW	VIS	TORNILLO
3	65	m	m	m	970 502 050		SCHLAUCH	37mm; 1 1/2"	TUBE	GAINÉ	TUBO
3	67	1	1	1	394 150 042		CHOKESTANGE		CHOKE SHAFT	LEVIER	PALANCE
3	68	m	m	m	965 452 382		SCHLAUCH	120mm; 4 3/4"	TUBE	GAINÉ	TUBO
3	69	1	1	1	965 401 016		GUMMITÜLLE		RUBBER BUSH	GAINÉ CAOUTCHOUC	BOQUILLA DE CAUCHO
3	72	1	1	1	395 174 120		DICHTUNG		GASKET	JOINT	JUNTA
3	73	1	1	1	395 174 110		ABSCHIRMBLECH		COOLING PLATE	TÔLE DE PROTECTION	CHAPA DEFLECTORA
3	74	2	2	2	908 405 205		SCHRAUBE INNEN6RD ZK	M5x20	H.L. SOCKET HEAD BOLT	VIS	TORNILLO
3	83	1	1	1	395 117 011		GASGESTÄNGE		THROTTLE LINKAGE	TRINGLE D' ACCÉLÉRATION	VARILLA ACELERADOR
3	86	1	1	1	957 395 001		REP.-SATZ CHOKEWELLE / KONTAKTFEDER		KIT CHOKE SHAFT / CONTACT SPRING	JEU AXE CLAPET D'AIR / RESSORT DE CONTACT	JUEGO EJE VÁLVULA AIRE / RESORTE DE CONTACTO
3	205	1	1	1	928 405 000		SPANNSCHEIBE		DISC	DISQUE	ARANDELA
3	213	1	1	1	908 005 125		INNENSTERN-SCHRAUBE	M5x12	SCREW	VIS	TORNILLO
3	266	1	1	1	038 111 060		4KT-MUTTER	M5, SW10	SQUARE NUT	ECROU CARRÉ	TUERCA CUADR.
3	268b	1	1	1	395 171 025		KOMPENSATIONSSCHLAUCH	l=138mm, red/black	TUBE	GAINÉ	TUBO
3	269	1	1	1	038 131 070		FEDERSCHELLE		HOSE CLIP	COLLIER DE SERRAGE	ABRAZADERA
3	270	1	1	1	394 131 200		ANSAUGSCHLAUCH		SUCTION HOSE	TUYAU D' ASPIRATION	TUBO DE ASPIRACIÓN
3	271	1	1	1	394 131 210		ANSAUGSCHLAUCH	SET	SUCTION HOSE	TUYAU D' ASPIRATION	TUBO DE ASPIRACIÓN
3	286	1	1	1	395 174 200		SCHALLDÄMPFER	SLR	MUFFLER	POT D' ÉCHAPPEMENT	SILENCIADOR
3	287	1	1	1	395 174 140		FUNKENSCHUTZSIEB	SLR	SPARK ARRESTER SCREEN	TAMIS	TAMIZ
3	288	1	1	1	913 242 100		INNEN-6KT-SCHRAUBE	4x9,7	ALLEN SCREW	BOULON À SIX PANS CREUX	TORNILLO DE CABEZA CON HEX. INTER.
3	294	1	1	1	320 324 616		SCHLAUCHKLEMME		HOSE CLAMP	COLLIER	ABRAZADERA

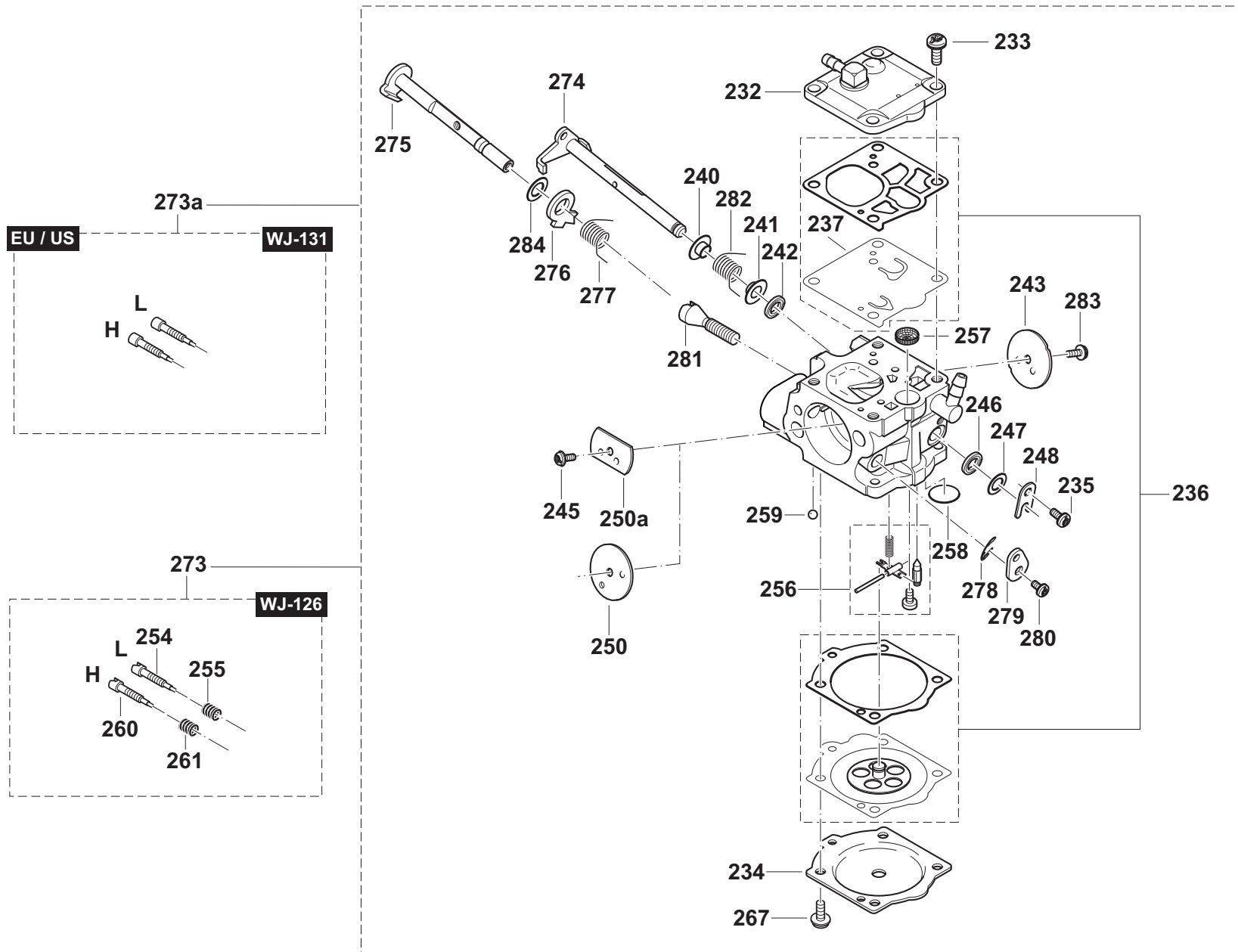

Seite / Page	Pos.	EK7300	EK7301	EK8100	Teil-Nr. Part No. No. de pièce No. de pieza	Hinweise Notes Renseign. Nota	Bezeichnung	Spezifikation Specification	Description	Désignation	Denominación
4	232	1	1	1	394 151 160		PUMPENDECKEL KPL.		PUMP COVER CPL.	COUVERCLE DE POMPE CPL.	TAPA DE BOMBA CPL.
4	233	4	4	4	144 150 170		SCHRAUBE		SCREW	VIS	TORNILLO
4	234	1	1	1	395 151 120		MEMBRANDECKEL		DIAPHRAGM COVER	COUVERCLE DE MEMBRANE	TAPA DE MEMBRANA
4	235	1	1	1	378 151 220		SCHRAUBE		SCREW	VIS	TORNILLO
4	236	1	1	1	957 151 180		MEMBRANSATZ		SET DIAPHRAGM / GASKETS	JEU DE MEMBRANES / JOINTS	JUEGO MEMBRANAS / JUNTAS
4	237	1	1	1	394 151 150		PUMPENMEMBRAN, GUMMI		PUMP DIAPHRAGM	MEMBR. DE POMPE	MEMBR. D. LA BOMBA
4	240	1	1	1	394 151 315		BUCHSE		BUSHING	DOUILLE	CASQUILLO
4	241	1	1	1	394 151 315		BUCHSE		BUSHING	DOUILLE	CASQUILLO
4	242	1	1	1	394 151 330		DICHTRING		PACKING RING	BAGUE-JOINT	ANILLO DE GUARNICIÓN
4	243	1	1	1	394 151 320		DROSSELKLAPPE		THROTTLE SHUTTER	CLAPET D' ÉTRANGLEMENT	VÁLVULA REGULADORA
4	245	1	1	1	394 151 660		SCHRAUBE		SCREW	VIS	TORNILLO
4	246	1	1	1	394 151 330		DICHTRING		PACKING RING	BAGUE-JOINT	ANILLO DE GUARNICIÓN
4	247	1	1	1	394 151 400		SCHEIBE		DISC	DISQUE	DISCO
4	248	1	1	1	108 151 350		WELLENSICHERUNG		SHAFT CLIP	TÔLE DE SÉCURITÉ	PIEZA SEGURIDAD ÁRBOL
4	250	1	1	1	395 151 260	=> 2013-12	CHOKEKLAPPE		CHOKE SHUTTER	CLAPET D' AIR	VÁLVULA DE AIRE
4	250a	1	1	1	395 151 265	2014-01 =>	CHOKEKLAPPE		CHOKE SHUTTER	CLAPET D' AIR	VÁLVULA DE AIRE
4	254	1	1	1	394 151 470		LEERLAUF-STELLSCHRAUBE	L	IDLE ADJUSTMENT SCREW	VIS DE RÉGL. DE RALENTI	TORNILLO REGULADOR
4	255	1	1	1	021 151 480		FEDER	L	SPRING	RESSORT	RESORTE
4	256	1	1	1	957 151 191		SATZ STEUERTEILE		CONTROL PARTS	PIÈCES DE COMM.	PIEZAS DE MANDO
4	257	1	1	1	021 151 180		SIEB		SCREEN	TAMIS	TAMIZ
4	258	1	1	1	394 151 040		VERSCHLUßSCHEIBE		COVER DISC	DISQUE DE FERMETURE	DISCO DE SIERRE
4	259	1	1	1	394 151 510		SICHERUNGSEINSATZ		LOCKING BALL	BILLE D' ARRÊT	BOLA DE TOPE
4	260	1	1	1	001 151 450		VOLLGAS-STELLSCHRAUBE	H	MAIN ADJUSTM. SCREW	VIS DE RÉGL. PLEIN GAZ	TORNILLO REGULADOR
4	261	1	1	1	021 151 480		FEDER	L	SPRING	RESSORT	RESORTE
4	267	4	4	4	378 151 220		SCHRAUBE		SCREW	VIS	TORNILLO
4	273	1	1	1	395 151 015		VERGASER	WJ-126c (non regulated market)	CARBURETOR	CARBURATEUR	CARBURADOR
4	273a	1	1	1	395 151 025		VERGASER	D, WJ-131A (EU, USA - regulated market)	CARBURETOR	CARBURATEUR	CARBURADOR
4	274	1	1	1	395 151 130		DROSSELKLAPPENWELLE		THROTTLE SHAFT	AXE CLAPET D ÉTRANG.	EJE VÁLVULA REG.
4	275	1	1	1	395 151 170		CHOKEWELLE		CHOKE SHAFT	AXE CLAPET D'AIR	EJE VÁLVULA AIRE
4	276	1	1	1	395 151 110		HALBGASHEBEL		FAST IDLE LEVER	LEVIER	PALANCA
4	277	1	1	1	395 151 190		DREHFEDER		TORSION SPRING	RESSORT DE TENSION	RESORTE DE TORSIÓN
4	278	1	1	1	119 151 350		WELLENSICHERUNG		SHAFT CLIP	TÔLE DE SÉCURITÉ	PIEZA SEGURIDAD ÁRBOL
4	279	1	1	1	395 151 180		CHOKEHEBEL		CHOKE LEVER	LEVIER DE STARTER	PALANCA ESTRANGULADOR DE AIRE
4	280	1	1	1	394 151 660		SCHRAUBE		SCREW	VIS	TORNILLO
4	281	1	1	1	395 151 140		LEERLAUF-ANSCHLAGSCHRAUBE	S	IDLE STOP SCREW	VIS DE BUTÉE DE RALENTI	TORNILLO DE TOPE
4	282	1	1	1	395 151 150		DREHFEDER		TORSION SPRING	RESSORT DE TENSION	RESORTE DE TORSIÓN
4	283	1	1	1	394 151 660		SCHRAUBE		SCREW	VIS	TORNILLO
4	284	1	1	1	170 151 290		SCHEIBE		WASHER	RONDELLE	ARANDELA

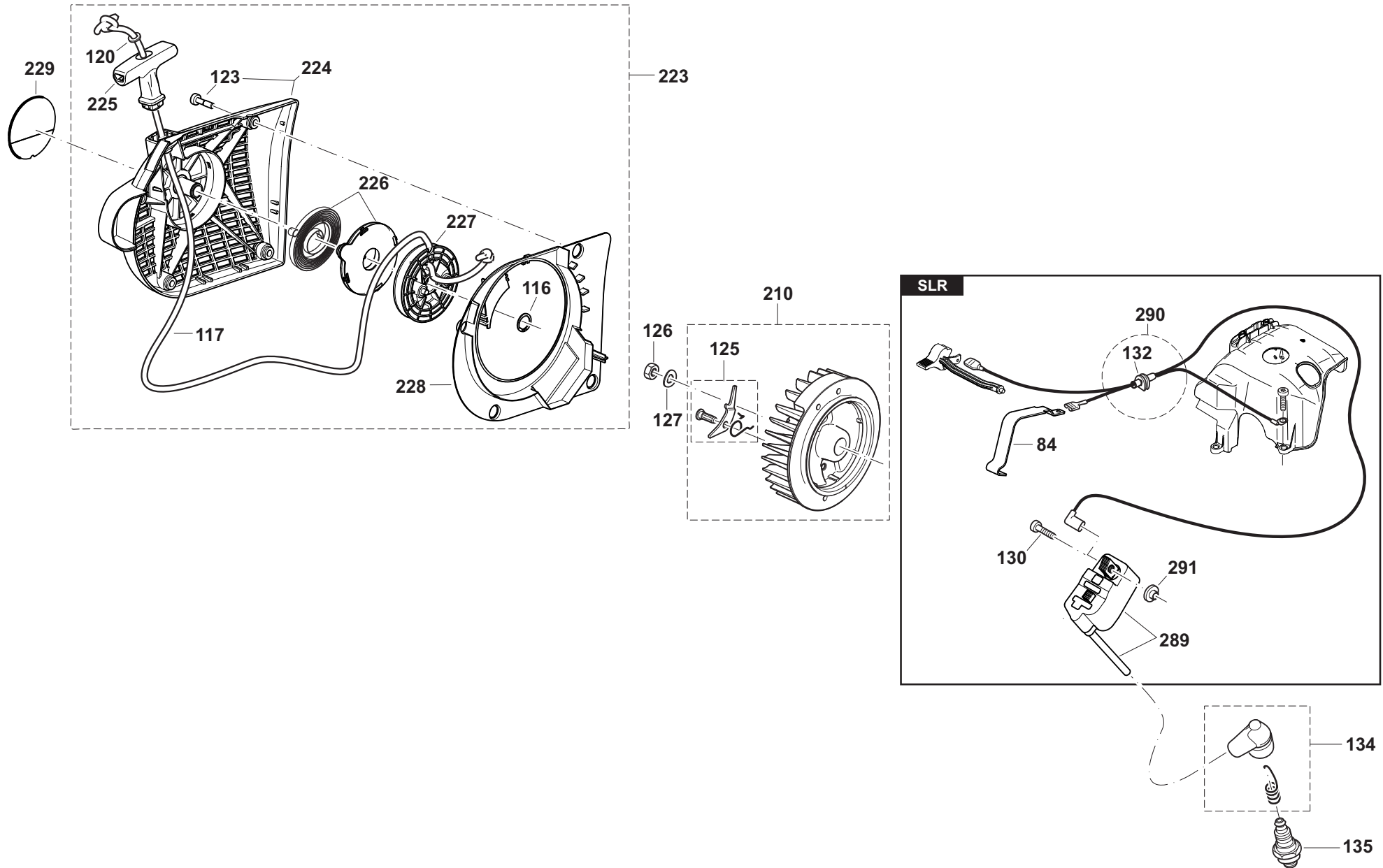

EK7300, EK7301, EK8100

5

Anwerfvorrichtung, Magnetzündler
 Starter assy., ignition assy.
 Dispositif de démarrage, volant magnétique
 Dispositivo arranque, volante magnético



Seite / Page	Pos.	EK7300	EK7301	EK8100	Teil-Nr. Part No. No. de pièce No. de pieza	Hinweise Notes Renseign. Nota	Bezeichnung	Spezifikation Specification	Description	Désignation	Denominación
5	84	1	1	1	957 395 001		REP.-SATZ CHOKEWELLE / KONTAKTFEDER		KIT CHOKE SHAFT / CONTACT SPRING	JEU AXE CLAPET D'AIR / RESSORT DE CONTACT	JUEGO EJE VÁLVULA AIRE / RESORTE DE CONTACTO
5	116	1	1	1	929 314 100		SICHERUNGSRING		SNAP RING	CIRCLIP	ANILLO SEGURIDAD
5	117	1	1	1	394 164 020		ANWERFSEIL SCHWARZ	ø4 x 1000mm	STARTER ROPE BLACK	CÂBLE DE DÉMARRAGE NOIR	CORDÓN DE ARRANQUE NEGRO
5	117	1	1	1	122 164 010		ANWERFSEIL	ø4 x 1000mm	STARTER ROPE	CÂBLE DE DÉMARRAGE	CORDÓN DE ARRANQUE
5	120	1	1	1	928 405 000		SPANNSCHEIBE		DISC	DISQUE	ARANDELA
5	123	4	4	4	908 605 205		SCHRAUBE INNEN6RD	M5x20	H.L. SOCKET HEAD BOLT	VIS	TORNILLO
5	125	2	2	2	031 166 010		ANWERFKLINKE KPL.		STARTER RATCHET CPL.	CLIQUET CPL.	TRINQUETE ARRANQUE CPL.
5	126	1	1	1	920 208 024		6KT-MUTTER	M8x1	HEXAGONAL NUT	ECROU HEXAGONAL	TUERCA HEXAGONAL
5	127	1	1	1	926 208 001		FEDERSCHEIBE	B8	SPRING WASHER	RONDELLE ÉLASTIQUE	DISCO AMORTIGUADOR
5	130	2	2	2	908 605 205		SCHRAUBE INNEN6RD	M5x20	H.L. SOCKET HEAD BOLT	VIS	TORNILLO
5	132	1	1	1	965 401 016		GUMMITÜLLE		RUBBER BUSH	GAINÉ CAOUTCHOUC	BOQUILLA DE CAUCHO
5	134	1	1	1	957 604 260		ZÜNDKERZENSTECKER KPL.		SPARK PLUG CAP CPL.	FICHE DE BOUGIE, CPL.	TAPA DE BUJIA CPL.
5	135	1	1	1	965 603 021		ZÜNDKERZE		SPARK PLUG	BOUGIE	BUJÍA
5	210	1	1	1	394 141 090		POLRAD KPL.		FLYWHEEL ASSY.	ROUE POLAIRE CPL.	VOLANTE ENCENDIDO
5	223	1	1	1	395 160 600	2010 =>	ANWERFVORRICHTUNG KPL. BLAU	blue, highly polished	STARTER ASSY. BLUE	DISPOS. DE DÉMARRAGE CPL. BLEU	DISPOS. DE ARRANQUE CPL. AZUL
5	224	1	1	1	395 160 630	2010 =>	STARTERGEHÄUSE, BLAU	blue, highly polished	HOUSING	CARTER	CÂRTER
5	225	1	1	1	181 164 010		ANWERFGRIFF		STARTER KNOB	POIGNÉE DE LANCEMENT	TIRADOR DE ARRANQUE
5	226	1	1	1	181 163 050		RÜCKHOLFEDER IM GEHÄUSE		REWIND SPRING IN HOUSING	RESSORT RAPPEL DANS BOÎT	RESORTE RETENC. EN CAJA
5	227	1	1	1	395 162 020		SEILTROMMEL KPL.		CABLE DRUM CPL.	TAMBOUR DE CÂBLE CPL.	TAMBOUR PARA CORDÓN CPL.
5	228	1	1	1	395 118 170		LUFTFÜHRUNG		AIR GUIDE PLATE	GUIDE D'AIR	CONDUCTO DE AIRE
5	229	1	1	1	980 115 760		SCHILD	MAKITA	LABEL	PLAQUE	CALCOMANIA
5	289	1	1	1	395 143 010		MAGNETZÜNDER		IGNITION COIL	BOBINE D' ALLUMAGE	BOBINA ENCENDIDO
5	290	1	1	1	965 605 514		KABEL MIT STECKER		CABLE WITH PLUG	CÂBLE AVEC PRISE	CABLE CON ENCHUFE
5	291	2	2	2	195 143 031		ISOLIERSCHEIBE	nature	ISOLATING WASHER	RONDELLE	ARANDELA

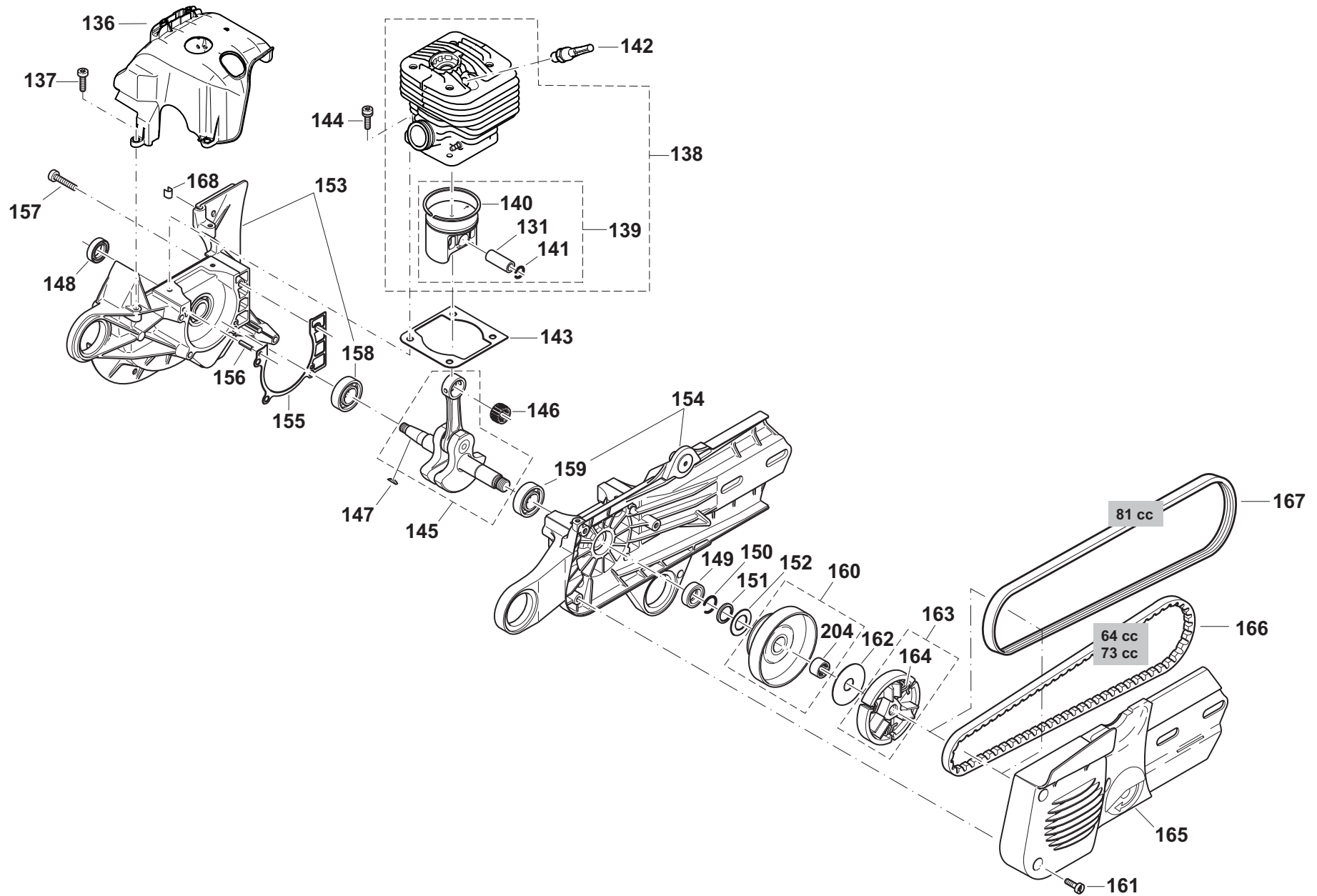

EK7300, EK7301, EK8100

6

Zylinder, Kurbeltrieb, Kupplung
Cylinder, crankshaft, clutch
Cylindre, vilebrequin, embrayage
Cilindro, cigüeñal, embrague



Seite / Page	Pos.	EK7300	EK7301	EK8100	Teil-Nr. Part No. No. de pièce No. de pieza	Hinweise Notes Renseign. Nota	Bezeichnung	Spezifikation Specification	Description	Désignation	Denominación
6	131	1	1		119 132 030		KOLBENBOLZEN		PISTON PIN	AXE DE PISTON	PERNO DE PISTÓN
6	131			1	038 132 040		KOLBENBOLZEN		PISTON PIN	AXE DE PISTON	PERNO DE PISTÓN
6	136	1	1	1	395 131 041		KÜHLLUFTHAUBE		COOLING HOOD	CAPOT	CUBIERTA
6	137	3	3	3	909 005 155		SCHRAUBE	M5x15	BOLT	VIS	TORNILLO
6	138	1	1		395 130 110		ZYLINDER / KOLBEN KPL.	ø 50 HeadDeco, SLR	CYLINDER / PISTON CPL.	CYLINDRE ET PISTON CPL.	CILINDRO CON PISTÓN CPL.
6	138			1	328 130 110		ZYLINDER / KOLBEN KPL.	ø 52 HeadDeco, SLR	CYLINDER / PISTON CPL.	CYLINDRE ET PISTON CPL.	CILINDRO CON PISTÓN CPL.
6	139	1	1		395 132 050		KOLBEN KPL.	ø 50	PISTON CPL.	PISTON CPL.	PISTÓN CPL.
6	139			1	328 132 100		KOLBEN KPL.	ø 52	PISTON CPL.	PISTON CPL.	PISTÓN CPL.
6	140	1	1		394 132 020		KOLBENRING	ø 50	PISTON RING	SEGMENT DE PISTON	SEGMENTO DE PISTÓN
6	140			1	038 132 020		KOLBENRING	ø 52	PISTON RING	SEGMENT DE PISTON	SEGMENTO DE PISTÓN
6	141	2	2		119 132 060		SPRENGRING	C12X1	SPRING RING	ANNEAU-RESSORT	ANILLO ELÁSTICO
6	141			2	038 132 080		SPRENGRING		CLIP	ANNEAU RESSORT	ANILLO ELÁSTICO
6	142	1	1	1	395 118 071		DEKOMPRESSIONSVENTIL	HeadDeco	VALVE	SOUPAPE	VÁLVULA
6	143	1	1	1	965 531 160		ZYLINDERFUßDICHTUNG, METALL		GASKET, METAL	JOINT, MÉTAL	JUNTA, METAL
6	144	4	4	4	908 805 235		INNENSTERNSCHRAUBE MIT SPANNSCHEIBE	M5x23	SCREW	VIS	TORNILLO
6	145	1	1		395 120 100		KURBELWELLE KPL.	SLR	CRANKSHAFT ASS'Y	VILEBREQUIN CPL.	CIGÜEÑAL CPL.
6	145			1	328 120 100		KURBELWELLE KPL.	SLR	CRANKSHAFT CPL.	VILEBREQUIN CPL.	CIGÜEÑAL CPL.
6	146	1	1	1	962 210 121		NADELKRANZ		NEEDLE CAGE	CAGE À AIGUILLES	JAULA DE AGUJAS
6	147	1	1	1	939 630 370		SCHEIBENFEDER		KEY	CLAVETTE	CHAVETA
6	148	1	1	1	962 900 052		RADIALDICHRING	ø15/24x7	RADIAL RING	JOINT RADIAL	JUNTA RADIAL
6	149	1	1	1	962 900 052		RADIALDICHRING	ø15/24x7	RADIAL RING	JOINT RADIAL	JUNTA RADIAL
6	150	1	1	1	930 916 160		SPRENGRING		SPRING RING	ANNEAU-RESSORT	ANILLO ELÁSTICO
6	151	1	1	1	394 245 010		ANSCHLAGRING, GEHÄRTET, VERZINKT		STOP RING	BAGUE DE BUTÉE	ANILLO DE DETEN.
6	152	1	1	1	394 182 020		FÜHRUNGSSCHEIBE		GUIDE DISC	DISQUE DE GUIDAGE	DISCO DE GUÍA
6	153	1	1	1	395 111 110		KURBELGEHÄUSE KPL. MS, SCHWARZ	incl. page 3: pos. 76,205,213	CRANKC., MAG. SIDE	CARTER-COTÉ, MAGN.	CÁRTER CIG., LADO MAG.
6	154	1	1	1	326 111 740		KURBELGEHÄUSE KPL. KS, SCHWARZ		CRANKC., CLUTCH SIDE	CARTER-COTÉ, EMBR.	CÁRTER CIG., LADO EMBR.
6	155	1	1	1	965 531 111		KURBELGEHÄUSEDICHTUNG		GASKET	JOINT	JUNTA
6	156	2	2	2	936 430 160		SPIRALSPANNSTIFT	3X16	CLAMPING PIN	GOUPILLE	PASADOR
6	157	5	5	5	908 005 305		INNENSTERN-SCHRAUBE	M5x30	SCREW	VIS	TORNILLO
6	158	1	1	1	960 102 152		KUGELLAGER (EINKLEBEN)	6202	BALL BEARING (USE GLUE)	ROULEMENT À BILLES (À COLLER)	RODAM. DE BOLAS (A COLAR)
6	159	1	1	1	960 102 152		KUGELLAGER (EINKLEBEN)	6202	BALL BEARING (USE GLUE)	ROULEMENT À BILLES (À COLLER)	RODAM. DE BOLAS (A COLAR)
6	160	1	1		394 223 025		KUPPLUNGSTROMMEL KPL.		CLUTCH DRUM CPL.	TAMBOUR CPL.	TAMBOR CPL.
6	160			1	326 223 023		KUPPLUNGSTROMMEL KPL.	ø400mm-80m	CLUTCH DRUM CPL.	TAMBOUR CPL.	TAMBOR CPL.
6	161	3	3	3	908 605 145		INNENSTERN-SCHLITZ-SCHRAUBE	M5x14	SCREW	VIS	TORNILLO
6	162	1	1	1	001 182 042		FÜHRUNGSSCHEIBE	44,5x1x12	DISC	DISQUE	DISCO
6	163	1	1	1	010 180 024		KUPPLUNG KPL.		CLUTCH ASSY.	EMBRAYAGE CPL.	EMBRAGUE CPL.
6	164	3	3	3	024 184 021		ZUGFEDER		SPRING	RESSORT	RESORTE
6	165	1	1	1	395 213 670	2010 =>	ABDECKUNG MIT SCHLITZEN, BLAU	blue, highly polished	COVER	COUVERCLE	CUBIERTA

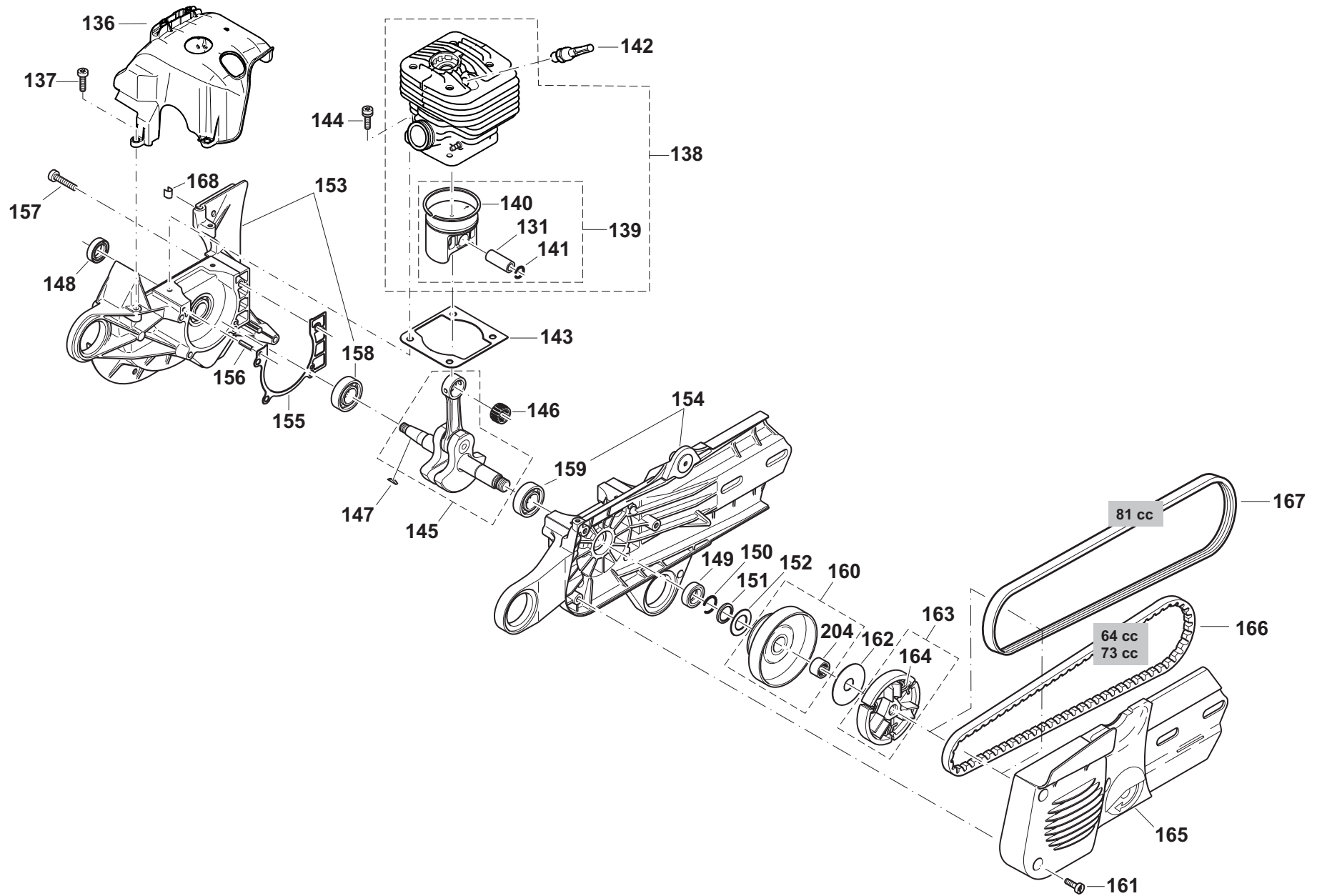

EK7300, EK7301, EK8100

6

Zylinder, Kurbeltrieb, Kupplung
 Cylinder, crankshaft, clutch
 Cylindre, vilebrequin, embrayage
 Cilindro, cigüeñal, embrague



Seite / Page	Pos.	EK7300	EK7301	EK8100	Teil-Nr. Part No. No. de pièce No. de pieza	Hinweise Notes Renseign. Nota	Bezeichnung	Spezifikation Specification	Description	Désignation	Denominación
6	166	1	1		965 300 470		KEILRIEMEN		V-BELT	COURROIE TRAPEZ	CORREA ESTRECHO
6	167			1	965 300 481		KEILRIPPENRIEMEN	ø400mm-80m	V-BELT	COURROIE TRAPEZ	CORREA ESTRECHO
6	168	1	1	1	965 402 870		FIXIERGUMMI	set=35 pcs.	RUBBER PLATE	PLAQUE DE CAOUTCH.	PLANCHA DE CAUCHO
6	204	1	1	1	962 300 017		NADELHÜLSE		NEEDLE BUSH	ROULEMENT À AIGUILLES	JAULA DE AGUJAS

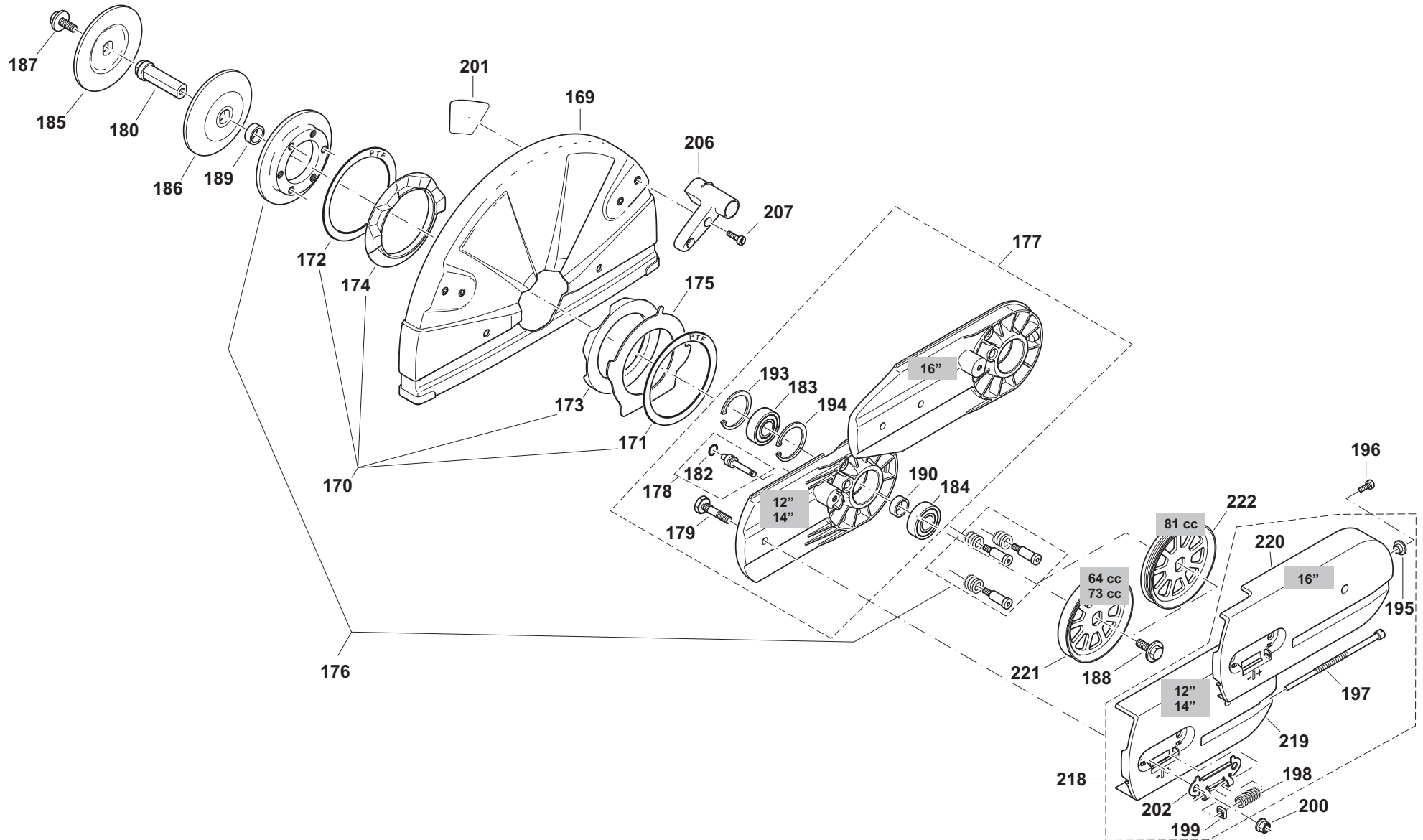

EK7300, EK7301, EK8100

7

Schneidvorsatz, Schutzhaube
Cutting device, protection hood
Dispositif de coupe, capot de protection
Dispositivo tronzadora, cubierta protectora



Seite / Page	Pos.	EK7300	EK7301	EK8100	Teil-Nr. Part No. No. de pièce No. de pieza	Hinweise Notes Renseign. Nota	Bezeichnung	Spezifikation Specification	Description	Désignation	Denominación
7	169	1			325 341 611		SCHUTZHAUBE, SILBER	ø 300mm; 12"	HOOD	CAPOT	CUBIERTA
7	169		1		394 341 051		SCHUTZHAUBE, SILBER	ø 350mm; 14"	HOOD	CAPOT	CUBIERTA
7	169			1	326 341 010		SCHUTZHAUBE, SILBER	ø 400mm; 16"	HOOD	CAPOT	CUBIERTA
7	170	1	1	1	957 342 011		AUFNAHME SCHUTZHAUBE KPL.		PROT. HOOD MOUNTING, CPL.	LOGEMENT CAPOT DE PROT. CPL.	ALOJAMIENTO CUB. PROT., CPL.
7	171	1	1	1	394 342 180		GLEITSCHIBE TEFLON		SLIDING DISC	DISQUE DE GLISSEMENT	ARANDELA DESLIZANTE
7	172	1	1	1	394 342 180		GLEITSCHIBE TEFLON		SLIDING DISC	DISQUE DE GLISSEMENT	ARANDELA DESLIZANTE
7	173	1	1	1	965 404 900		GUMMIRING AUßEN		RUBBER RING EXT.	BAGUE EN CAOUTCHOUC EXT.	ANILLO DE GOMA EXTERIOR
7	174	1	1	1	965 404 920		GUMMIRING INNEN		RUBBER RING INT.	BAGUE EN CAOUTCHOUC INT.	ANILLO DE GOMA INTERIOR
7	175	1	1	1	394 342 160		ANSCHLAGBLECH		IMPACT PLATE	TÔLE DE BUTÉE	CHAPA DE TOPE
7	176	1	1	1	394 342 211		DRUCKRING KPL., SCHWARZ		PRESSURE RING CPL.	BAGUE DE PRESSION CPL.	ANILLO DE PRESIÓN CPL.
7	177	1	1		394 211 740		SCHNEIDVORSATZ KPL., SCHWARZ	12", 14"	CUTTING DEVICE ASSY.	DISPOSITIF DE COUPE CPL.	DISPOS. TRANZADORA CPL.
7	177			1	326 211 740		SCHNEIDVORSATZ KPL., SCHWARZ	16"	CUTTING DEVICE ASSY.	DISPOSITIF DE COUPE CPL.	DISPOS. TRANZADORA CPL.
7	178	1	1	1	394 342 190		ANSCHLAGBOLZEN KPL.		BOLT CPL.	BOULON CPL.	BULON CPL.
7	179	2	2	2	394 211 091		BEFESTIGUNGSBOLZEN		TIGHTEN LOCKING BOLT	BOULON DE FIXATION	PERNO DE FIJACIÓN
7	180	1	1	1	394 228 101		ACHSE	ø 20mm	AXLE	AXE	EJE
7	180	1	1	1	394 228 130	Acc.	ACHSE	ø 22,2mm	AXLE	AXE	EJE
7	180	1	1	1	394 228 111		ACHSE	ø 25,4mm; 1"	AXLE	AXE	EJE
7	182	1	1	1	963 209 020		O-RING	9x2	PACKING RING	BAGUE-JOINT	ANILLO DE GUARNICIÓN
7	183	1	1	1	960 102 176		KUGELLAGER		BALL BEARING	ROULEMENT À BILLES	RODAMIENTO DE BOLAS
7	184	1	1	1	960 102 176		KUGELLAGER		BALL BEARING	ROULEMENT À BILLES	RODAMIENTO DE BOLAS
7	185	1	1	1	326 228 020		SPANNFLANSCH	12"-16"	PRESSURE DISC	DISQUE DE PRESSION	DISCO DE PRESIÓN
7	186	1	1	1	326 228 020		SPANNFLANSCH	12"-16"	PRESSURE DISC	DISQUE DE PRESSION	DISCO DE PRESIÓN
7	187	1	1	1	994 280 250		6KT-SCHRAUBE	M8x25	HEXAGONAL SCREW	VIS HEXAGONAL	TORNILLO HEXAGONAL
7	188	1	1	1	994 280 250		6KT-SCHRAUBE	M8x25	HEXAGONAL SCREW	VIS HEXAGONAL	TORNILLO HEXAGONAL
7	189	1	1	1	394 228 022		DISTANZHÜLSE		SPACER	DOUILLE DE DISTANCE	CASQUILLO SEPARADOR
7	190	1	1	1	394 228 022		DISTANZHÜLSE		SPACER	DOUILLE DE DISTANCE	CASQUILLO SEPARADOR
7	193	1	1	1	929 240 180		SICHERUNGSRING		SNAP RING	CIRCLIP	ANILLO SEGURIDAD
7	194	1	1	1	929 240 180		SICHERUNGSRING		SNAP RING	CIRCLIP	ANILLO SEGURIDAD
7	195			1	326 211 020		BUCHSE		BUSHING	DOUILLE	CASQUILLO
7	196			1	908 905 125		INNEN-6KT-SCHRAUBE	5x12	SCREW	VIS	TORNILLO
7	197	1	1	1	394 213 032		SPANNSCHRAUBE		TENSIONING SCREW	VIS DE TENSION	TORNILLO DE TENSION
7	198	1	1	1	394 342 120		DRUCKFEDER		COMPRESSION SPRING	RESSORT DE PRESSION	RESORTE DE PRESIÓN
7	199	1	1	1	921 906 004		4KT-MUTTER	M6	SQUARE NUT	ECROU CARRÉ	TUERCA CUADR.
7	200	2	2	2	923 208 004		6KT-MUTTER	M8	HAXAGONAL NUT	ECROU HEXAGONAL	TUERCA HEXAGONAL
7	201	1			980 114 972		SICHERHEITSAUFKLEBER	ø300/20,0mm; ø12"/.787"	SAFETY LABEL	PLAQUE	CALCOMANIA
7	201		1		980 114 975		SICHERHEITSAUFKLEBER	ø350/25,4mm; ø14"/1"	SAFETY LABEL	PLAQUE	CALCOMANIA
7	201		1		980 114 974		SICHERHEITSAUFKLEBER	ø350/20,0mm; ø14"/.787"	SAFETY LABEL	PLAQUE	CALCOMANIA
7	201			1	980 115 226		SICHERHEITSAUFKLEBER	ø400/20,0mm; ø16"/.787"	SAFETY LABEL	PLAQUE	CALCOMANIA
7	201		1		980 115 615	RU	SICHERHEITSAUFKLEBER	ø350/20,0mm; ø14"/.787"	SAFETY LABEL	PLAQUE	CALCOMANIA

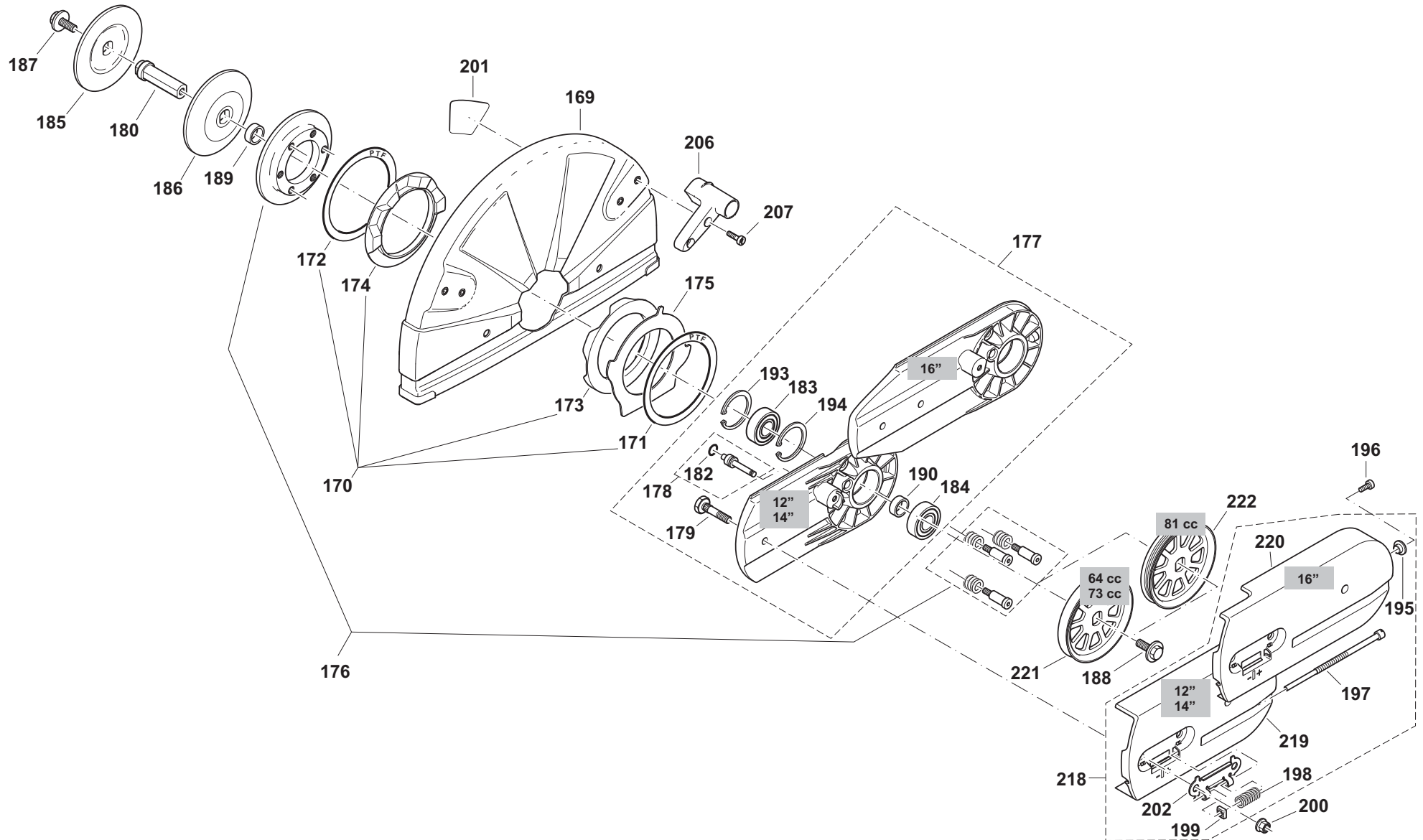

EK7300, EK7301, EK8100

7

Schneidvorsatz, Schutzhaube
Cutting device, protection hood
Dispositif de coupe, capot de protection
Dispositivo tranzadora, cubierta protectora



Seite / Page	Pos.	EK7300	EK7301	EK8100	Teil-Nr. Part No. No. de pièce No. de pieza	Hinweise Notes Renseign. Nota	Bezeichnung	Spezifikation Specification	Description	Désignation	Denominación
7	202	1	1	1	394 213 021		AUFNAHMEBLECH		METAL SHEET	TÔLE	CHAPA
7	206	1	1	1	326 341 301		GRIFF SCHUTZHAUBE		GRIP FOR PROTECTIVE HOOD	POIGNÉE POUR CAPOT DE PROTECT.	ASA PARA LA CAPOTA DE PROTECC.
7	207	2	2	2	908 605 165		INNENSTERN-SCHLITZ-SCHRAUBE	M5x16	SCREW	VIS	TORNILLO
7	218	1	1		395 211 640	2010 =>	ABDECKUNG SCHNEIDVORS. KPL., BLAU	12", 14", blue, highly polished	COVER CPL.	COUVERCLE CPL.	CUBIERTA CPL.
7	218			1	395 211 650	2010 =>	ABDECKUNG SCHNEIDVORS. KPL., BLAU	16", blue, highly polished	COVER CPL.	COUVERCLE CPL.	CUBIERTA CPL.
7	219	1	1		395 211 620	2010 =>	ABDECKUNG SCHNEIDVORS., BLAU	12", 14", blue, highly polished	COVER	COUVERCLE	CUBIERTA
7	220			1	395 211 630	2010 =>	ABDECKUNG SCHNEIDVORS., BLAU	16", blue, highly polished	COVER	COUVERCLE	CUBIERTA
7	221	1	1		394 221 050		KEILRIEMENSCHLEIBE		BELT PULLEY	POULIE	POLEA
7	222			1	326 221 020		KEILRIPPENSCHLEIBE		BELT PULLEY	POULIE	POLEA

EK7300, EK7301, EK8100

8

Trennscheiben, Werkzeug
Blades, tools
Disques, outils
Discos para dividir, herramientas

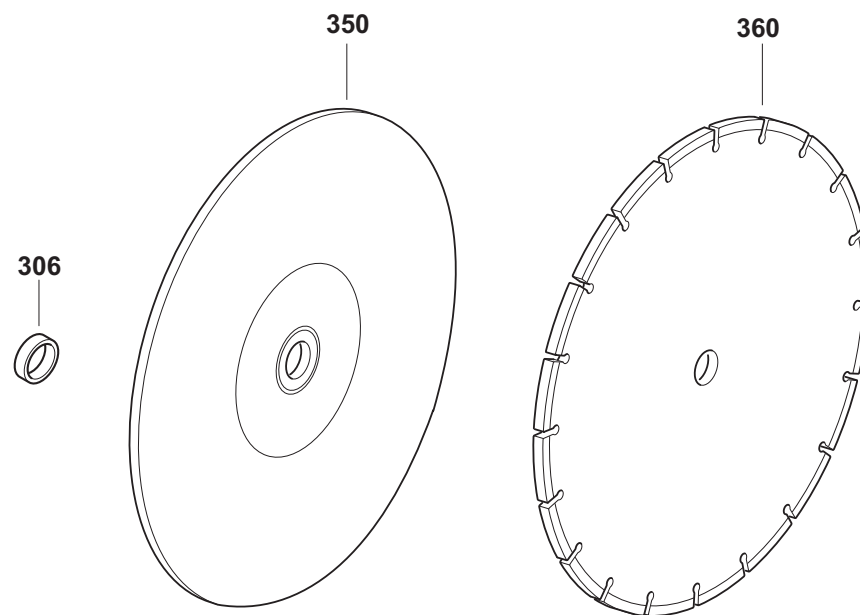
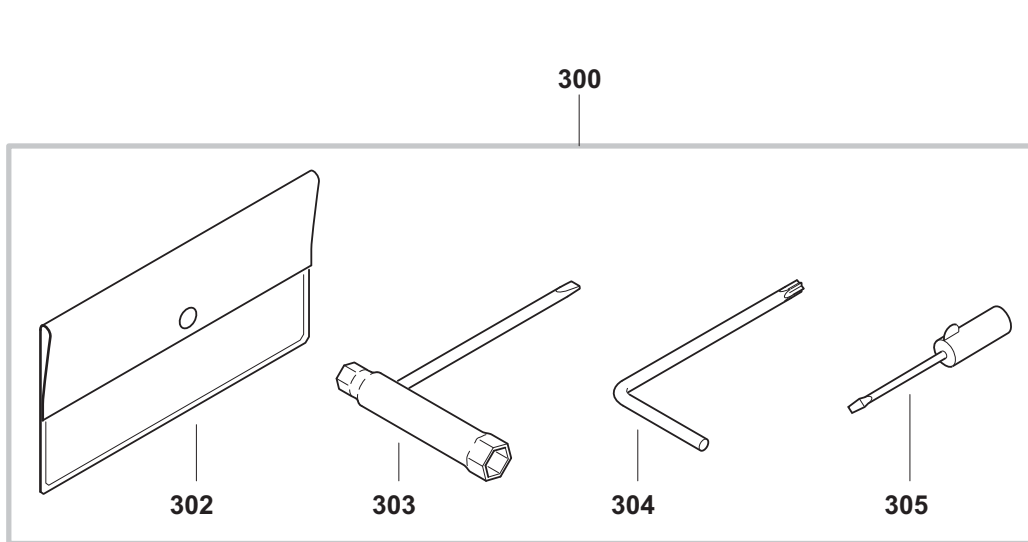

EK7300, EK7301, EK8100

8

Trennscheiben, Werkzeug
Blades, tools
Disques, outils
Discos para dividir, herramientas



Seite / Page	Pos.	EK7300	EK7301	EK8100	Teil-Nr. Part No. No. de pièce No. de pieza	Hinweise Notes Renseign. Nota	Bezeichnung	Spezifikation Specification	Description	Désignation	Denominación
8	300	1	1	1	957 004 006		WERKZEUG KPL.		TOOLS CPL.	OUTILS CPL.	HERRAMIENTAS CPL.
8	302	1	1	1	950 004 002		WERKZEUGTASCHE		PLASTIK BAG	POCHETTE EN PLASTIQUE	CÁRTERA HERRAMIENTAS
8	303	1	1	1	941 719 140		KOMBISCHLÜSSEL	SW 13/19 mm	UNIVERSAL WRENCH	CLÉ COMBINÉE	LLAVE DE BUJIA
8	304	1	1	1	940 827 000		WINKELSCHRAUBENDREHER	T27	ANGLED SCREW DRIVER	CLÉ ANGLE	LLAVE ANGULAR
8	305	1	1	1	944 340 001		SCHRAUBENDREHER		SCREWDRIVER	TOURNEVIS	DESTORNILLADOR
8	306	1	1	1	394 228 121	Acc.	ADAPTERRING	ø 20/25,4 mm	ADAPTER	ADAPTATEUR	ADAPTOR
8	350	1			966 121 150		TRENNSCHEIBE HARZ, STAHL	300/20mm; 12"	ABRAS. BLADE, STEEL	DISQUE SYNTH. ACIER	DISCO SINT. ACERO
8	350	1			966 121 120		TRENNSCHEIBE HARZ, STEIN	300/20mm; 12"	ABRAS. BLADE, STONE	DISQUE SYNTH. BÉTON	DISCO SINT. PEDRA
8	350		1		966 141 150		TRENNSCHEIBE HARZ, STAHL	350/20mm; 14"	ABRAS. BLADE, STEEL	DISQUE SYNTH. ACIER	DISCO SINT. ACERO
8	350		1		966 141 120		TRENNSCHEIBE HARZ, STEIN	350/20mm; 14"	ABRAS. BLADE, STONE	DISQUE SYNTH. BÉTON	DISCO SINT. PEDRA
8	350		1		966 144 150		TRENNSCHEIBE HARZ, STAHL	350/25,4mm; 14"	ABRAS. BLADE, STEEL	DISQUE SYNTH. ACIER	DISCO SINT. ACERO
8	350		1		966 144 120		TRENNSCHEIBE HARZ, STEIN	350/25,4mm; 14"	ABRAS. BLADE, STONE	DISQUE SYNTH. BÉTON	DISCO SINT. PEDRA
8	350			1	966 161 050		TRENNSCHEIBE HARZ, STAHL	400/20mm; 16"	ABRAS. BLADE, STEEL	DISQUE SYNTH. ACIER	DISCO SINT. ACERO
8	350			1	966 161 020		TRENNSCHEIBE HARZ, STEIN	400/20mm; 16"	ABRAS. BLADE, STONE	DISQUE SYNTH. BÉTON	DISCO SINT. PEDRA
8	350			1	966 164 050		TRENNSCHEIBE HARZ, STAHL	400/1"; 16"	ABRAS. BLADE, STEEL	DISQUE SYNTH. ACIER	DISCO SINT. ACERO
8	360	1				Acc.	TRENNSCHEIBE DIAMANT	ø 300mm/12"	DIAMOND BLADE	DISQUE DIAMANT	DISCO DIAMANTE
8	360		1			Acc.	TRENNSCHEIBE DIAMANT	ø 350mm/14"	DIAMOND BLADE	DISQUE DIAMANT	DISCO DIAMANTE
8	360			1		Acc.	TRENNSCHEIBE DIAMANT	ø 400mm/16"	DIAMOND BLADE	DISQUE DIAMANT	DISCO DIAMANTE

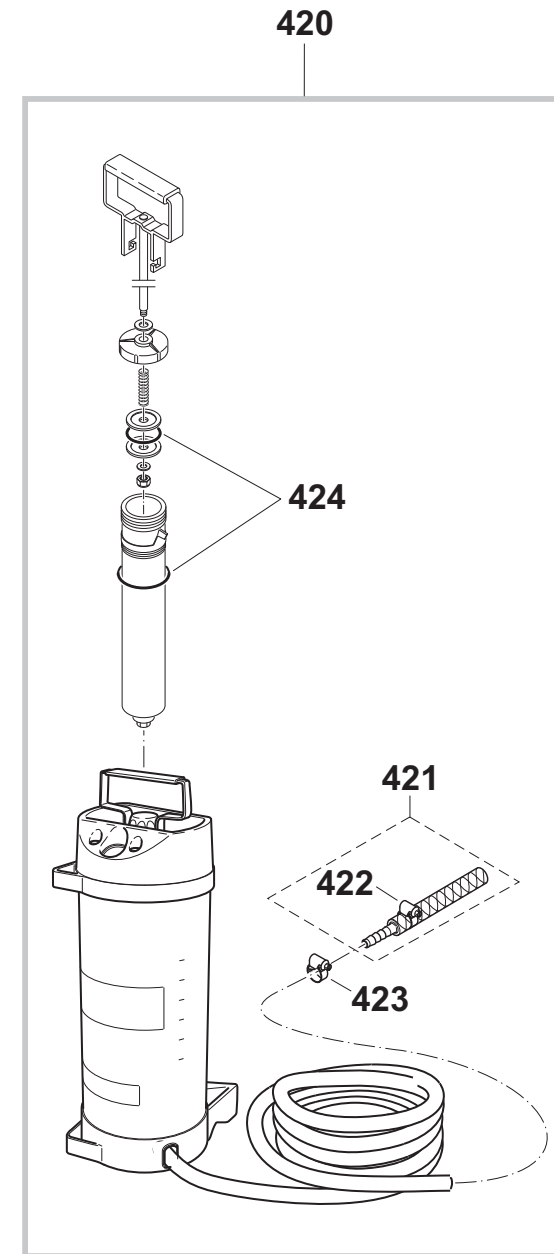
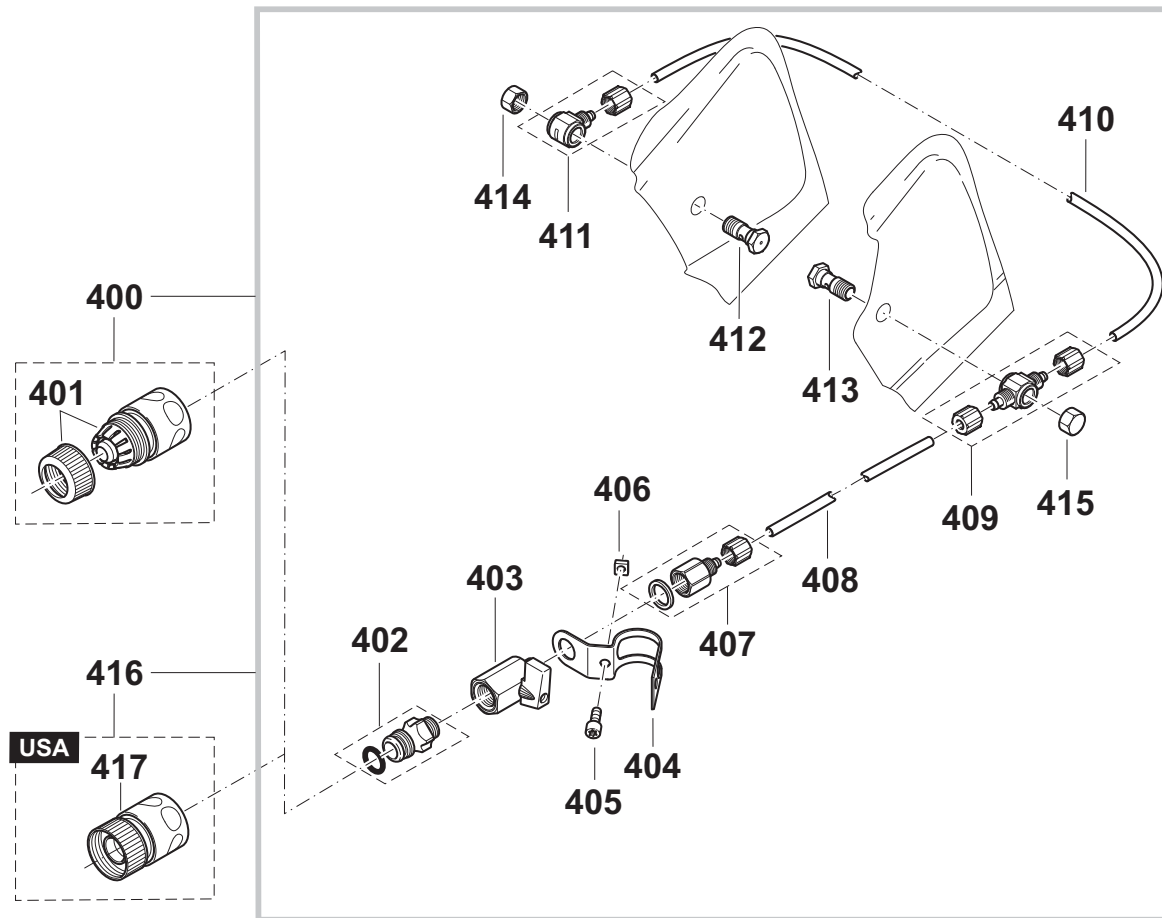

EK7300, EK7301, EK8100

9

Wasseranschluß, Druckwassertank • Nicht im Lieferumfang
 Water attachment, pressurised water tank • Not included in delivery
 Raccordement d'eau, réservoir d'eau sous pres. • Non incl. dans la livraison
 Acometida de agua, tanque de agua a pres. • No incluidos en entrega



Seite / Page	Pos.	EK7300	EK7301	EK8100	Teil-Nr. Part No. No. de pièce No. de pieza	Hinweise Notes Renseign. Nota	Bezeichnung	Spezifikation Specification	Description	Désignation	Denominación
9	400	1	1	1	394 365 102		DRUCK-, FALLWASSERARMATUR		WATER ATTACHMENT KIT	JEU DE RACCORDEMENT D'EAU	ACOMETIDA DE AGUA
9	401	1	1	1	964 802 271		SCHLAUCHKUPPLUNG	STOP	COUPLING SLEEVE	MANCHON D'ACCOUPLLEMENT	ACOPLAMIENTO P. TUBOS
9	402	1	1	1	964 802 282		EINSCHRAUBNIPPEL		HOSE CONNECTOR	RACCORD POUR TUYAU	BOQUILLA ROSCADA
9	403	1	1	1	964 802 291		KUGELVENTIL		SHUT OFF COCK	ROBINET D'ARRÊT	LLAVE DE PASO
9	404	1	1	1	394 365 163		SHELLE		CLAMP	BRIDE DE FIXATION	ABRAZADERA
9	405	1	1	1	909 006 145		SCHRAUBE	M6x14	SCREW	VIS	TORNILLO
9	406	1	1	1	921 906 004		4KT-MUTTER	M6	SQUARE NUT	ECROU CARRÉ	TUERCA CUADR.
9	407	1	1	1	964 802 410		SCHNELLVERSCHRAUBUNG		CONNECTING PIECE	PIÈCE DE RACCORD	PIEZA DE UNIÓN
9	408	m	m	m	964 802 322		PU-SCHLAUCH	405mm; 16"	HOSE	TUYAU	TUBO
9	409	1	1	1	964 802 332		SCHNELLVERSCHRAUBUNG	T	CONNECTING PIECE	PIÈCE DE RACCORD	PIEZA DE UNIÓN
9	410	m			964 802 322		PU-SCHLAUCH	180mm; 7"	HOSE	TUYAU	TUBO
9	410		m	m	964 802 322		PU-SCHLAUCH	210mm; 8 1/4"	HOSE	TUYAU	TUBO
9	411	1	1	1	964 802 342		SCHNELLVERSCHRAUBUNG	L	CONNECTING PIECE	PIÈCE DE RACCORD	PIEZA DE UNIÓN
9	412	1	1	1	964 802 352		HOHLSCHRAUBE GEBOHRT		HOLLOW SCREW, BORED	VIS	TORNILLO
9	413	1	1	1	964 802 352		HOHLSCHRAUBE GEBOHRT		HOLLOW SCREW, BORED	VIS	TORNILLO
9	414	1	1	1	964 802 362		HUTMUTTER		CAP NUT	ÉCROU BORGNE	TUERCA
9	415	1	1	1	964 802 362		HUTMUTTER		CAP NUT	ÉCROU BORGNE	TUERCA
9	416	1	1	1	394 365 630	U.S.A.	DRUCK-, FALLWASSERARMATUR		WATER ATTACHMENT KIT	JEU DE RACCORDEMENT D'EAU	ACOMETIDA DE AGUA
9	417	1	1	1	964 802 400	U.S.A.	SCHLAUCHKUPPLUNG	STOP 1 1/16"	COUPLING SLEEVE	MANCHON D'ACCOUPLLEMENT	ACOPLAMIENTO P. TUBOS
9	420	1	1	1	957 802 600		DRUCKWASSERTANK	10 l	PRESSURISED WATER TANK	RÉSERVOIR D'EAU SOUS PRES.	TANQUE DE AGUA A PRES.
9	421	1	1	1	394 365 180		SCHLAUCHADAPTER		CONNECTING REDUCER	RACCORD RÉDUCTEUR	REDUCTOR
9	422	1	1	1	964 802 250		SCHLAUCHSCHELLE	ø10-16 mm	HOSE CLIP	COLLIER DE SERRAGE	ABRAZADERA
9	423	1	1	1	964 802 250		SCHLAUCHSCHELLE	ø10-16 mm	HOSE CLIP	COLLIER DE SERRAGE	ABRAZADERA
9	424	1	1	1	957 963 200		DICHTUNGSSATZ		GASKET SET	JEU DE JOINTS	JUEGO JUNTAS

EK7300, EK7301, EK8100



	Zeichenerklärung	Key to symbols	Légende	Explicación de símbolos
<p>=> 1999999 2000000 => 2003.04 => TI 2003/07 Acc. = { m Corr.</p>	<p>Produktion bis Serien-Nr. Neues Teil ab Serien-Nr. Neues Teil ab Jahr / Monat Siehe Technische Information Jahr / Nr. Zubehör (nicht im Lieferumfang) Keine Serienausführung, jedoch verwendbar Beinhaltet Positions-Nr. Meterware Druckfehlerberichtigung</p>	<p>Production to serial number New part from serial number New part from Year / Month See Technical Information Year / No. Accessories (not included in the delivery inventory) No standard execution, may be used Contains item number Sold by the meter Error correction</p>	<p>Production jusqu'à n° de série Nouveau pièce à partir du n° de série Nouveau pièce à partir de année / mois Voir information technique année / n° Accessoires (non compris dans la livraison) Aucune exécut. en série, cependant utilisable contient n° de numéro Au mètre Rectification d'erreurs</p>	<p>Producción hasta N° de serie Pieza nueva a partir de N° de serie Pieza nueva a partir de año / mes Véase inform. técnico año / N° Accesorios (no incluido en la extensión del suministro) No es de serie, pero sirve Contiene pos N° Por metro Fe de erratas</p>
	Änderungen vorbehalten	Specifications subject to change without notice	Changements sans préavis	Mejoras constructivas sin previo aviso